

RIGHT VIEW

1

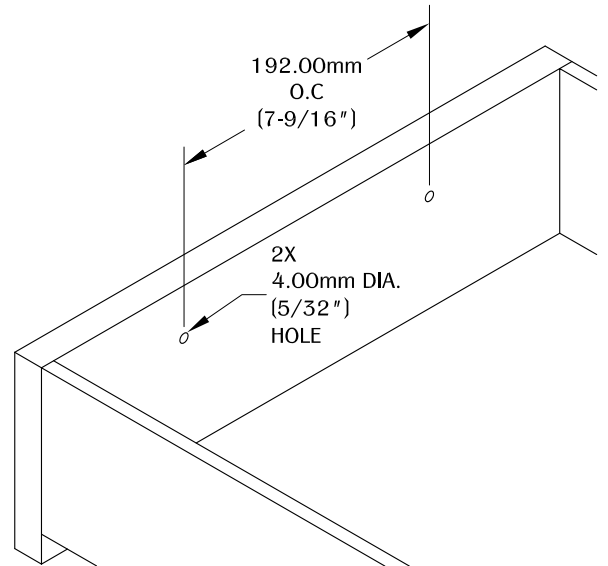

Determine the position and location of the part in the work surface. Mark the mounting positions and drill the holes for the mounting hardware.

2

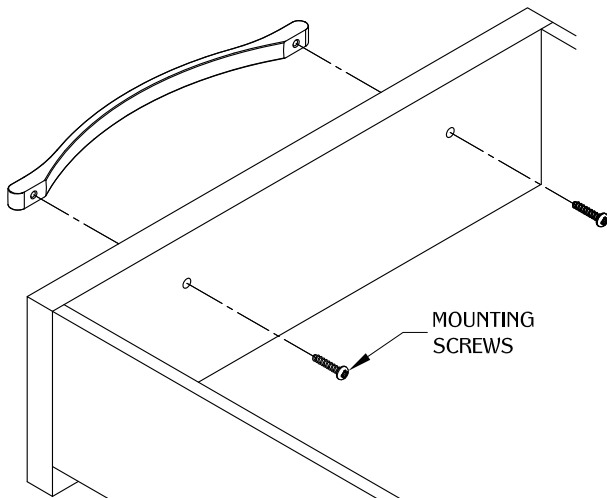

Use (2) screws to secure the part in to the work surface. Make sure the part is fully level on the work surface.

NOTE:

- Additional mounting screw lengths available upon request.
- All dimensions have a +/- 1/16" tolerance. We do not recommend drilling or cutting any holes before receiving a product or a product sample.

3

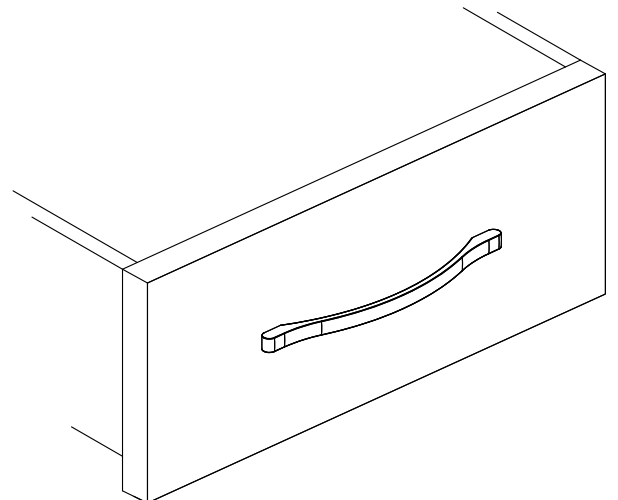



TABLE OF CONTENTS:

	1X DP286
	2X 1" 4mm-70 thread Machine screws