

NOTES:

1. 3/4" thick WOOD SHELF ONLY.
2. 12" MAX. shelf projection.
3. 36" MAX. shelf length.
4. Weight capacity per shelf projection;
6" shelf is 100 lbs., 8" shelf is 60 lbs.,
10" shelf is 40 lbs., & 12" shelf is 25 lbs.
5. Must install into studs.

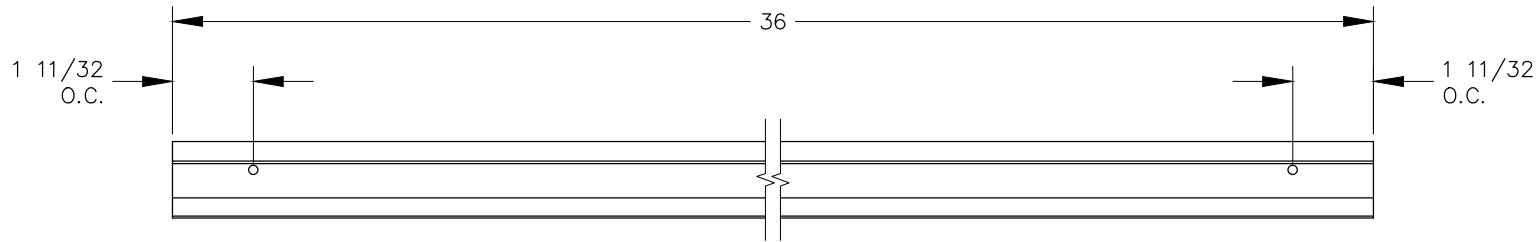

TOP VIEW

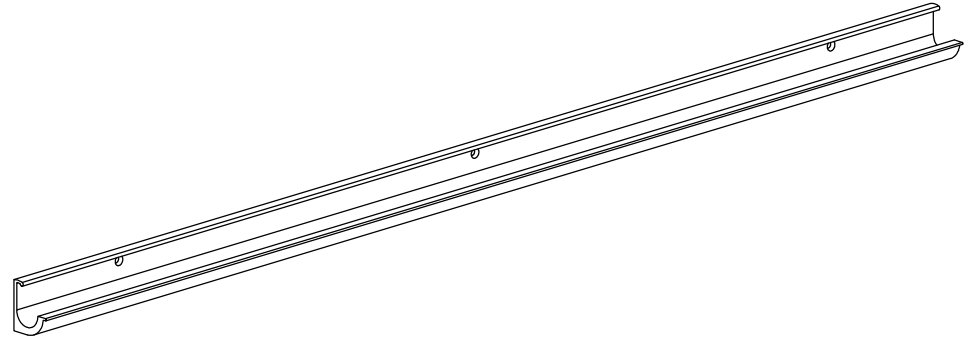
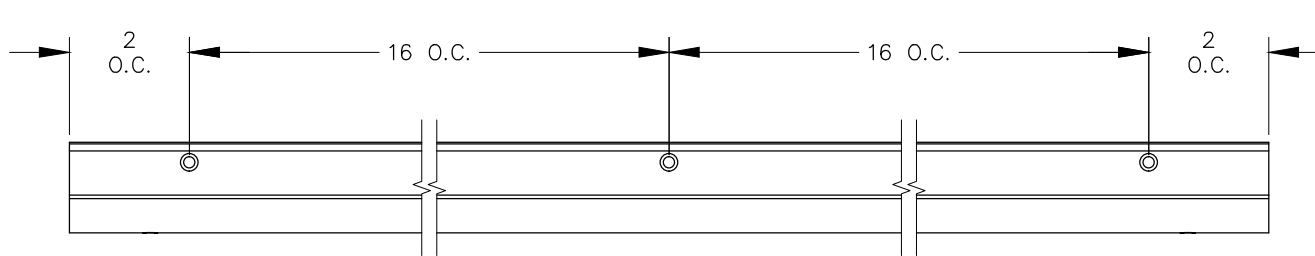

FRONT VIEW

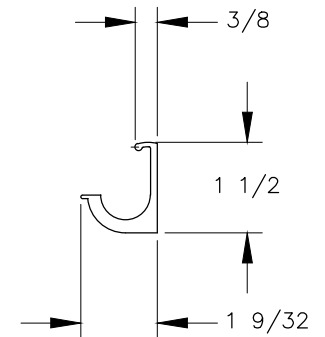

RIGHT VIEW