

TOP VIEW

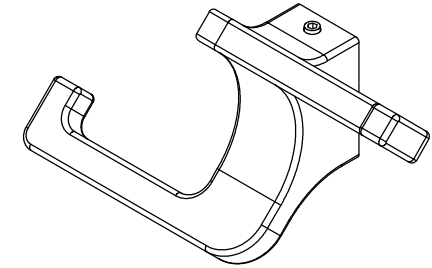

NOTE:

1. Weight capacity is 25 lbs.
2. Recommend installing into stud.

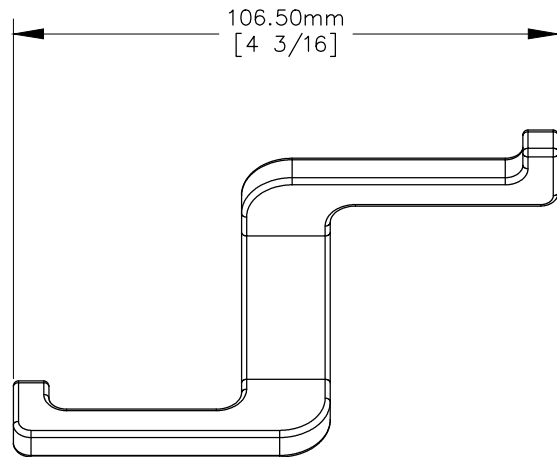

FRONT VIEW

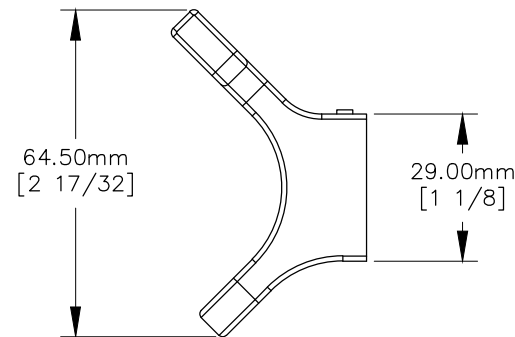

SIDE VIEW

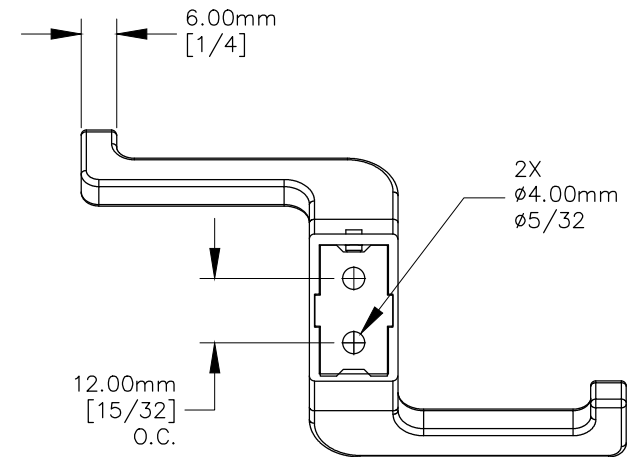

REAR VIEW