

1

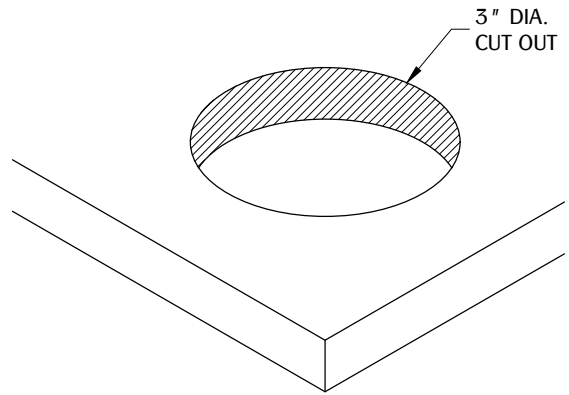

Make a cut out on the desired surface. (Note: We do not recommend cutting before receiving part or part sample.)

2

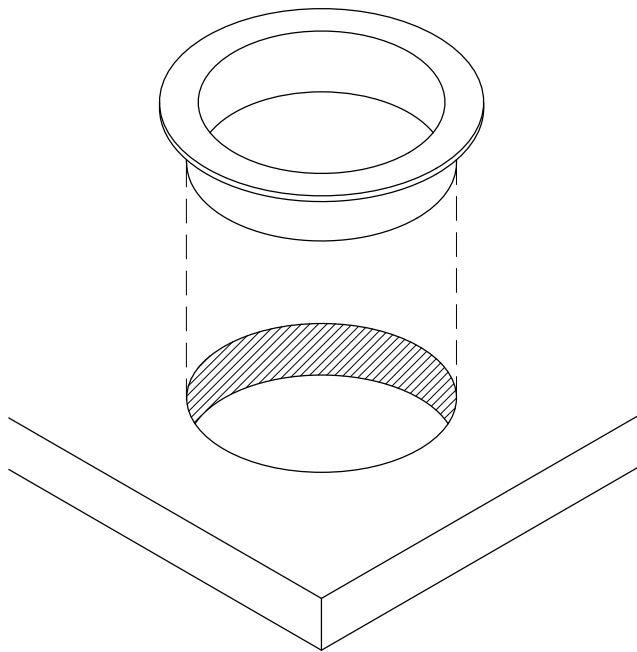

Install XG1 into the cut out and be sure it is fully leveled onto worksurface.

3

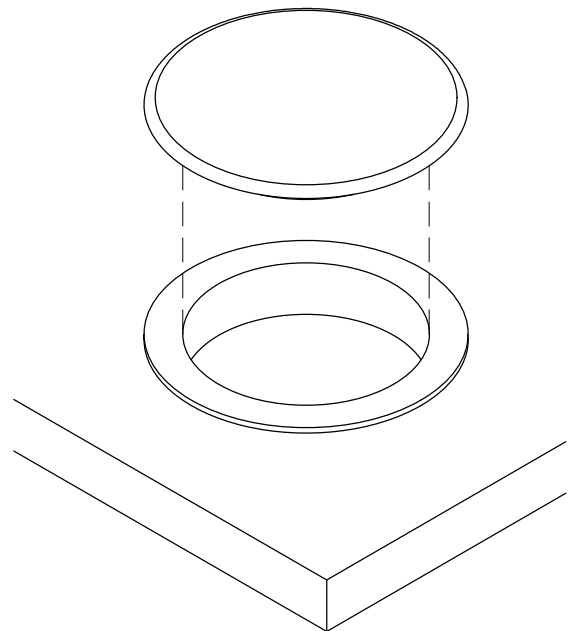

Insert XGW2 into the liner.

TABLE OF CONTENTS:

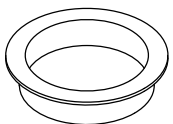

..... 1x XG1



..... 1x XGW2