

1

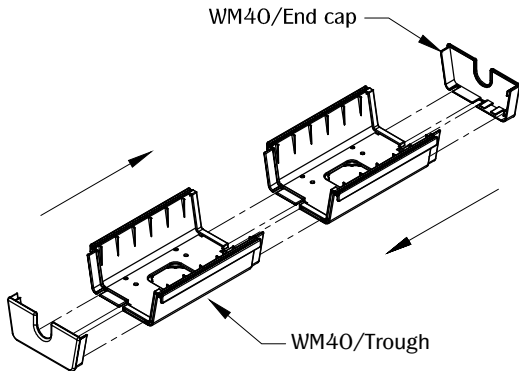

Align and snap (2) WM40/Trough and (2) WM40/End caps.

2

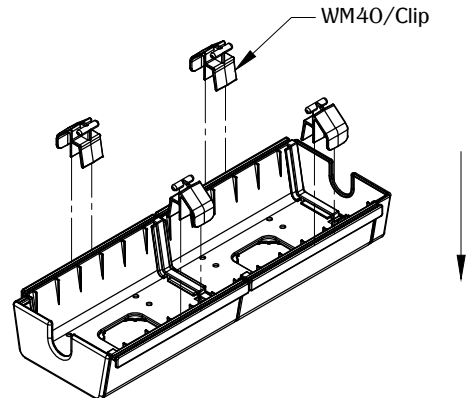

Snap (4) of the WM40/Clip to the top edge of the trough.

3

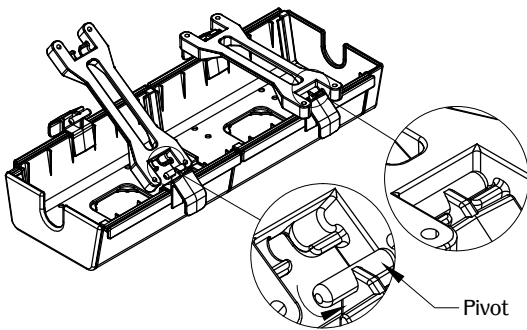

Hook the (2) WM40/Bracket under the pivot on top of the clips.

4

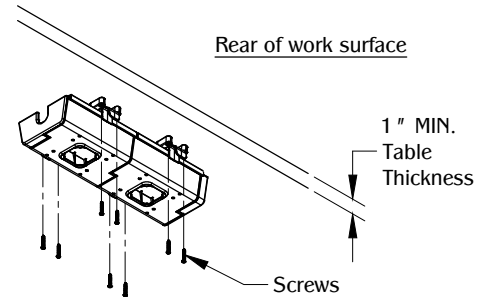

Use (8) screws to secure the part under the work surface. (Note: Minimum set back from rear edge of the work surface is 2-1/2". Recommended table thickness is 1".)

5 A)

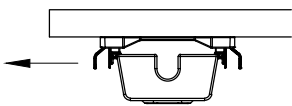

B)

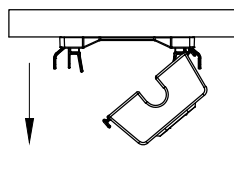

Pull the WM40/clip out and down to unhook the trough from the bracket. Place and guide wires in the trough; close when finished.

6

OPTIONAL

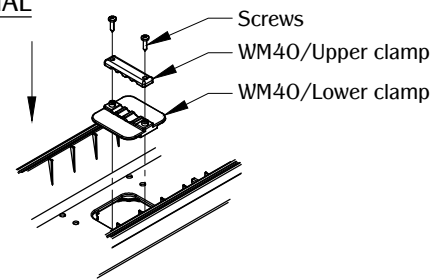

Use (2) screws to secure the cable in between upper and lower clamp assembly. Snap the assembly into the opening in the trough.

TABLE OF CONTENTS:

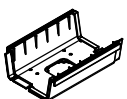

.....2 X WM40/Trough



.....2 X WM40/Bracket



.....2 X 3/4" Pan head screw



.....4 X WM40/Clip



.....8 X 1-1/4" Pan head screw



.....1 X WM40/Upper Cable clamp



.....2 X WM40/End cap



.....1 X WM40/Lower Cable clamp