

Determine the position and location on the work surface in which to apply the WM25. The WM25 can be used as a surface, under, or side mount.

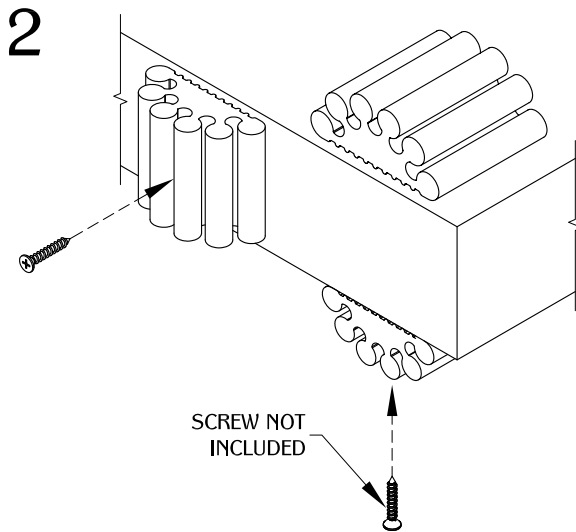

Drill a hole through the center groove of the WM25 before attaching to the work surface. Using a screw, drill through the hole that was created in the groove, attaching the unit to the work surface. Applying an adhesive to the base surface of the WM25 may be used as an alternative installation method to avoid drilling.

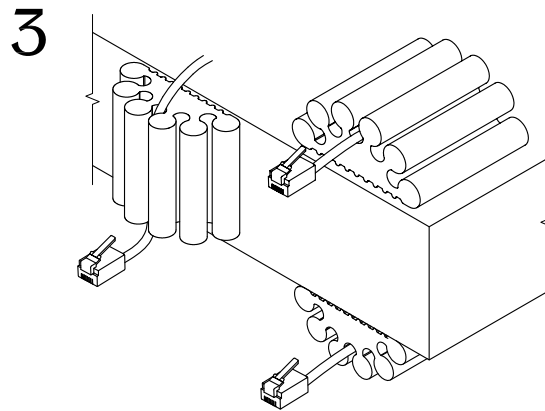

Place wires into position by slipping them through the grooves of the WM25.

TABLE OF CONTENTS:

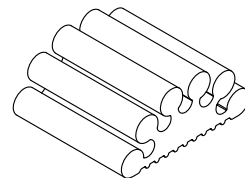

..... WM25