

SIDE VIEW

1a Adhesive Installation

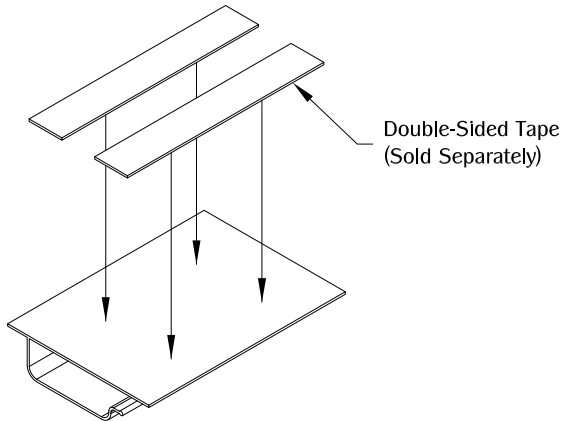

Apply adhesive or double-sided tape to the top of the part. If purchased with double-sided tape pre-installed, proceed to step 2.

2a

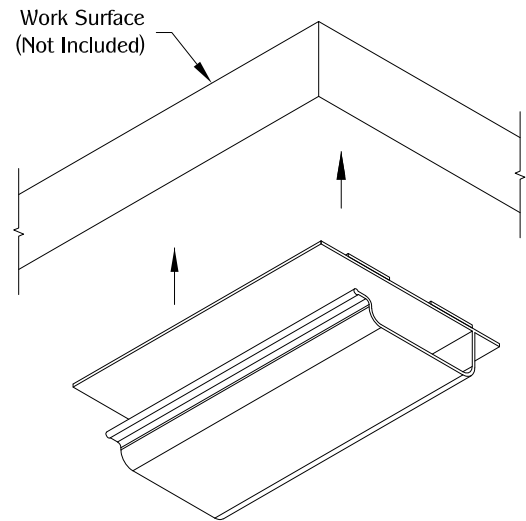

Determine the position and location of the part underneath the work surface. Peel the adhesive backing on the double-sided tape. Place part on desired work surface and make sure the part is fully leveled onto the work surface.

3a

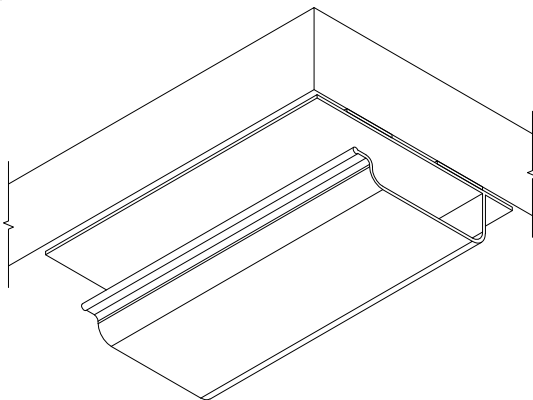

4a

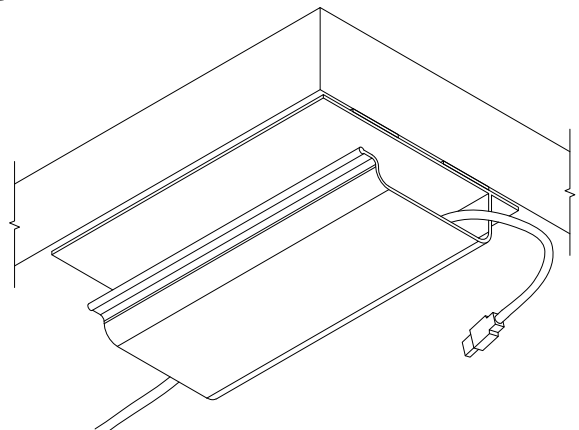

1b Screw Installation

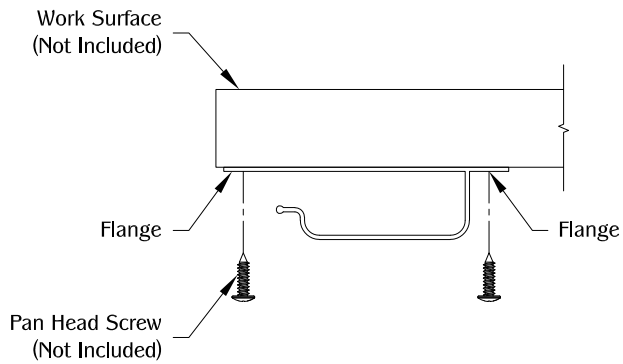

Determine the position and location of the part underneath the work surface. Place part on desired work surface and secure by drilling pan head screws along the flanges. Make sure the part is fully leveled onto the work surface. (Note: Use appropriate screws and screw length depending on the table type and thickness.)

2b

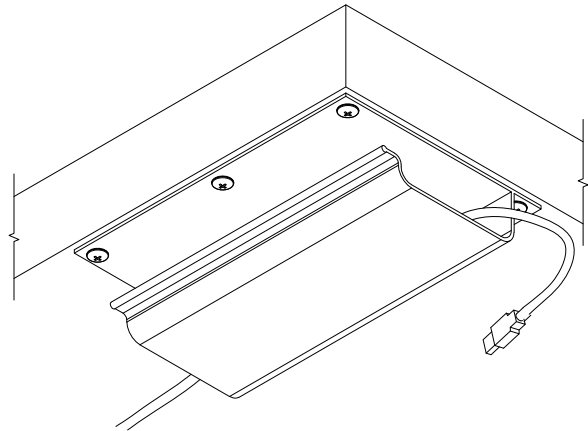

Place wires into position by slipping them through the small opening on the WM22A.