

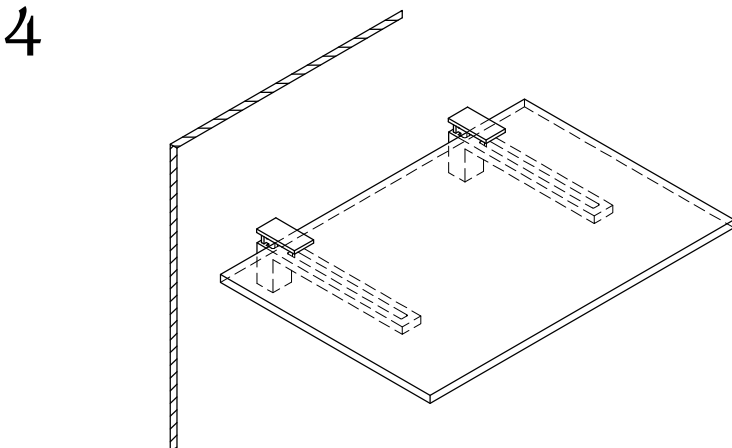

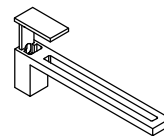

NOTE: 30 lbs. per bracket when installed into stud, 15 lbs. for drywall



NOTE: Recommended bracket spacing is no more than 24" apart, 8" maximum shelf depth.

TABLE OF CONTENTS:

	1x SH48A
	4x PADS
	1x SCREW
	2x WOOD SCREW
	2x PLASTIC ANCHOR