

FRONT VIEW

2

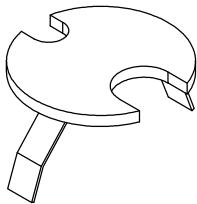

ADD ADHESIVE AND INSERT SLEEVE ALLOWING A 1/8" SPACE FOR CAP TO FIT FLUSH WITH SURFACE

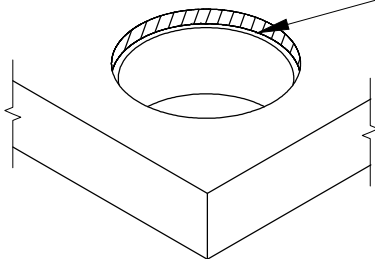

4

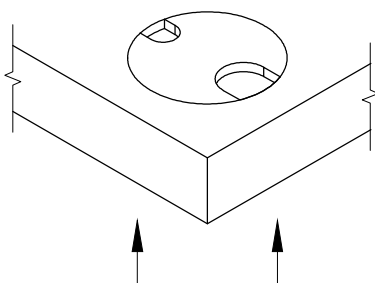

NOTE: IN ORDER TO REMOVE STEEL CAP YOU WOULD NEED TO PUSH FROM THE BOTTOM UP.

1

7/8" MIN. TABLE THICKNESS

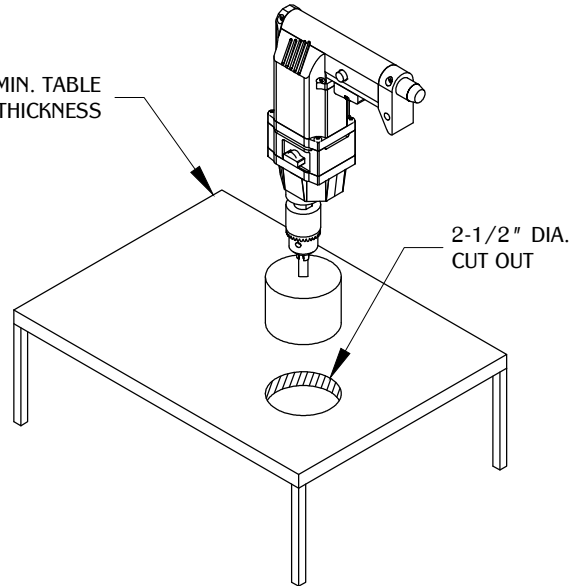

Make a cut out on the desired surface. (Note: We do not recommend cutting before receiving part or part sample.)

3

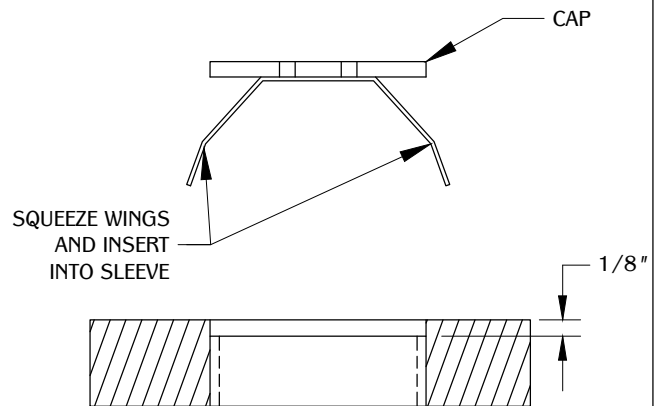
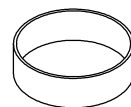

TABLE OF CONTENTS:



..... 1X PS-2C CAP



..... 1X PS-2C SLEEVE