

FRONT VIEW

1

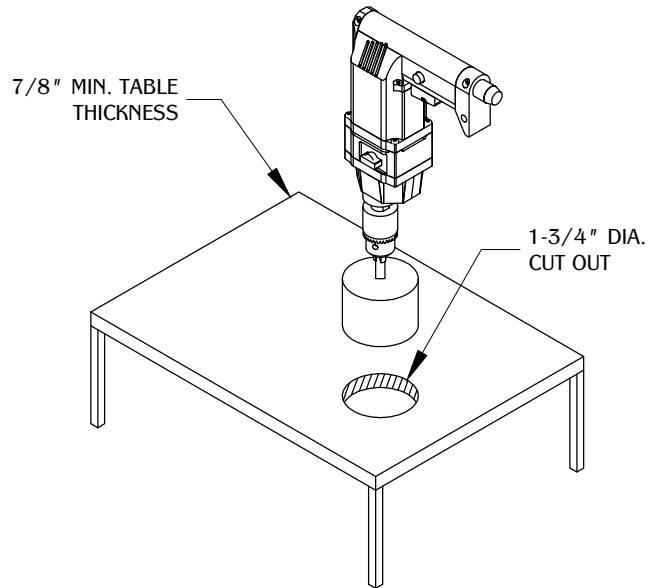

Make a cut out on the desired surface. (Note: We do not recommend cutting before receiving part or part sample.)

2

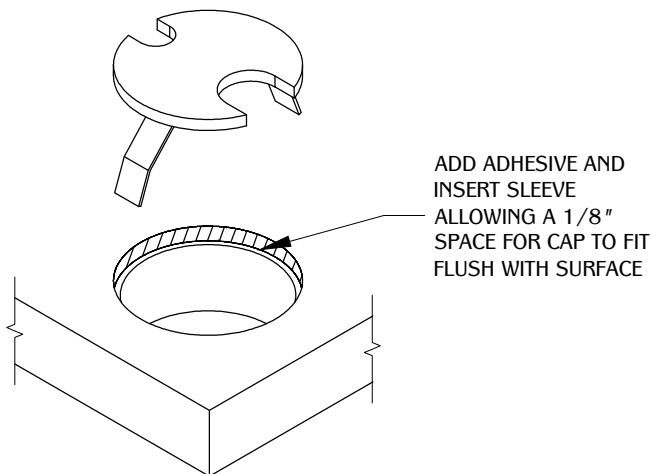

ADD ADHESIVE AND INSERT SLEEVE ALLOWING A 1/8" SPACE FOR CAP TO FIT FLUSH WITH SURFACE

3

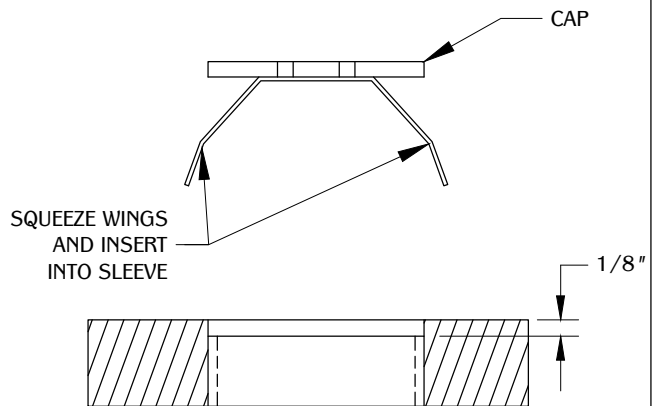

SQUEEZE WINGS AND INSERT INTO SLEEVE

4

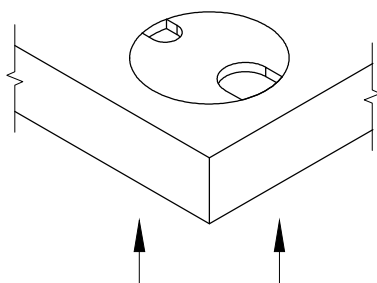

NOTE: IN ORDER TO REMOVE STEEL CAP YOU WOULD NEED TO PUSH FROM THE BOTTOM UP.

TABLE OF CONTENTS:



..... 1X PS-1C CAP



..... 1X PS-1C SLEEVE