

\*\*\*NOTE:  
Must use the plastic insert for 3/8" and 1/4" thick panel.

1

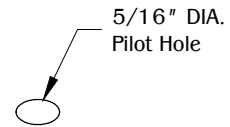

NOTE:  
1" Min. to 1-1/2" Max. table thickness.

Determine the position and location of the unit on the work surface. Drill a pilot hole through the work surface.

2

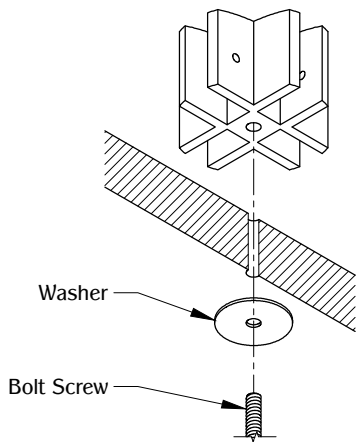

Secure the part using a 1/4" - 20 thread screw and washer.

3

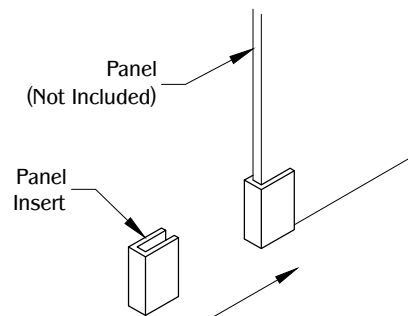

NOTE:  
Maximum panel height 18".



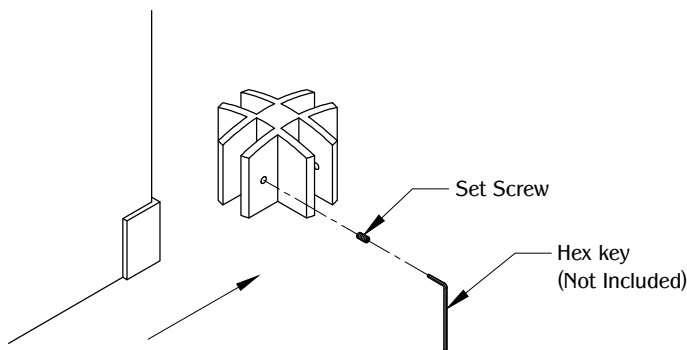

Determine the panel thickness. Attach the insert at the bottom corner of the panel. (Must use plastic inserts for 1/4" or 3/8" panel.)

4



Slide the panel with the insert into the grooves of the part. Secure the panel with the set screw. (Repeat Steps #3 & #4 for other panels.)

TABLE OF CONTENTS:

	.....1 X PGRP7
	.....4 X Set screw
	.....1 X 1-1/2" DIA. Washer
	.....1 X 2" Bolt Screw