

1

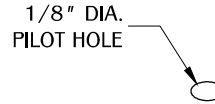

Determine the position and location of the part in the work surface. Drill a pilot hole.

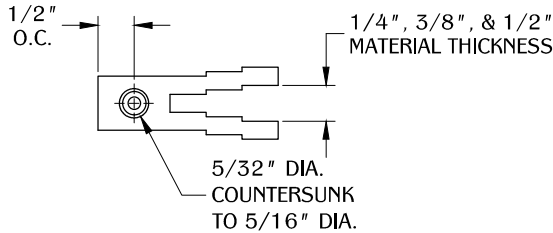

2

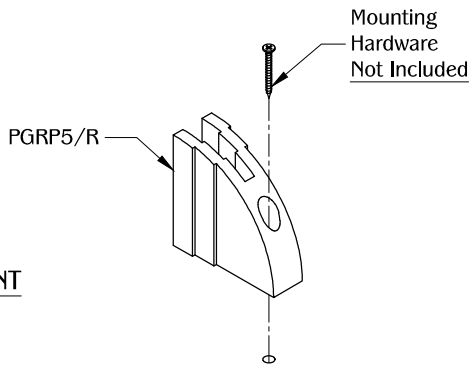

3

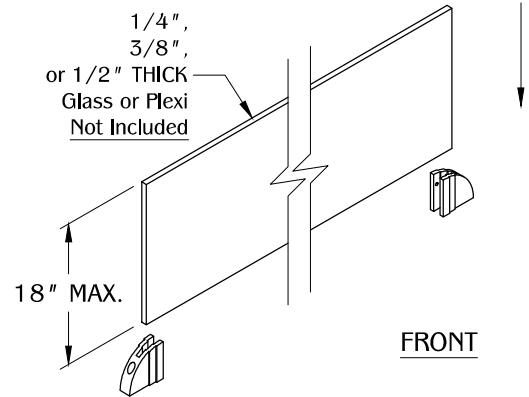

Align the PGRP5/R to the pre-drilled pilot hole. Make sure the part is fully level on the work surface. Secure the part by using a mounting hardware. (NOTE: Repeat Step #1 for the PGRP5/L and make sure both are aligned.)

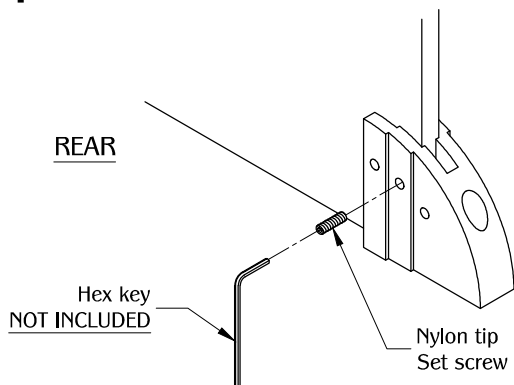

Insert your material (glass/display panel/etc) into the PGRP5 opening.

4



Use the hex key to secure the material with the set screw. (Note: Check tightness of screws periodically over time to ensure parts are securely tightened.)

TABLE OF CONTENTS:

1X PGRP5/L
1X PGRP5/R
2X 1/4" 10-24 Thread Nylon-tip set screw