

1

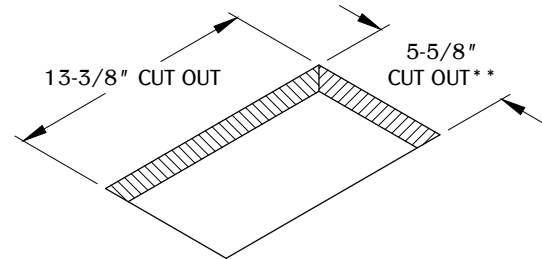

Determine the position and location of the unit on the work surface. Cut the hole at 13-3/8" X 5-5/8" ** from the top. (Note: We do not recommend drilling or cutting any holes before receiving a product or a product sample.)

2

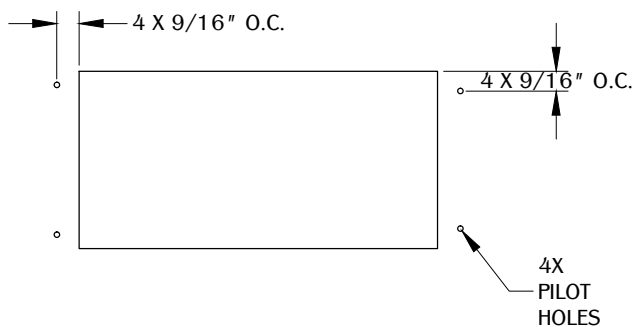

Drill (4) pilot holes to mount the unit under the work surface.

3

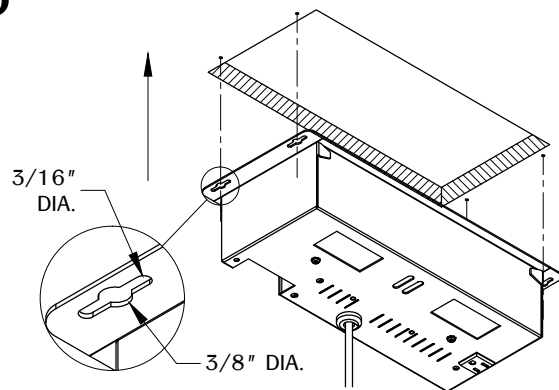

Align the unit mounting holes with the pilot holes. Secure the unit with the mounting hardware. (Mounting hardware not included.)

NOTE:

1. Mounting Hardware not included.
2. Plug the unit into nearby outlet where power cord is not taut or strained.
3. **Custom Lid add an extra 1/8" from the front of the unit.