

## PCS91/U1HW

310.318.2491 • 800.523.1269 • www.mockett.com

**NOTE:**  
Unit should be installed by a professional electrician.

 USB plugs for CHARGING USE ONLY.

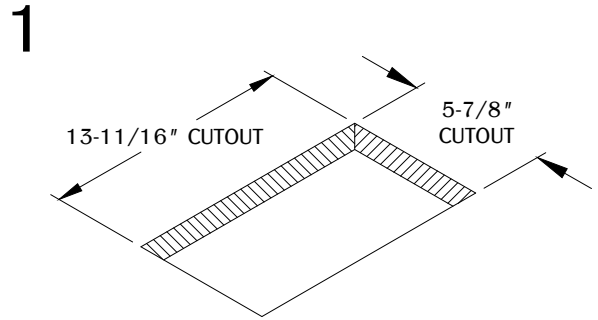
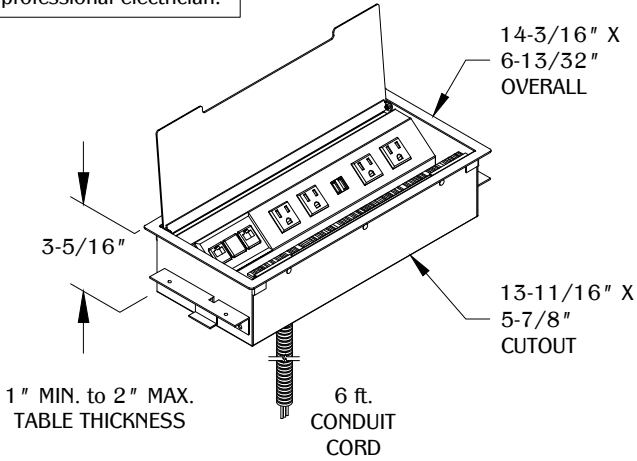

1 Determine the position and location of the unit on the work surface. Cut the hole at 13-11/16" X 5-7/8" from the top.

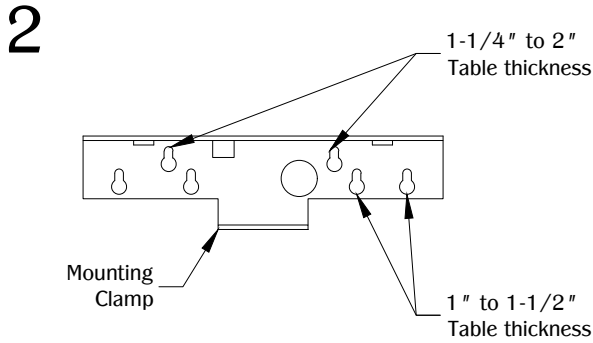

2 Determine the table thickness. Use the recommended guide above for the key slots on the mounting bracket.

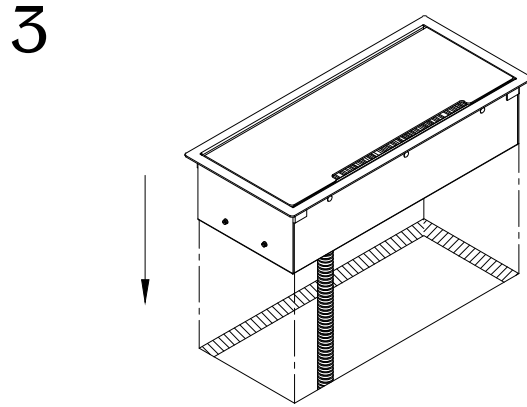

3 Install the unit into the cutout and be sure it is fully level on the surface.

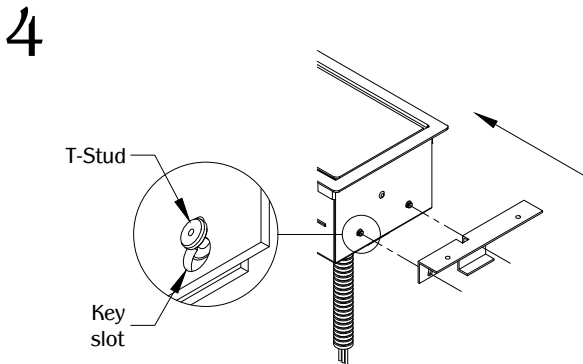

4 Align the mounting bracket key slots to the T-studs under the unit.

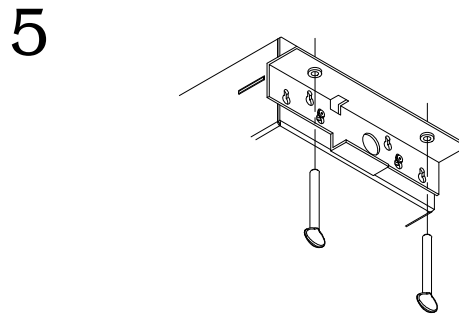

5 Tighten the (4) thumb screws on the mounting bracket. Connect the hardwires (Hardwire connection MUST comply with local electrical code.) and unit is ready for use.

TABLE OF CONTENTS:

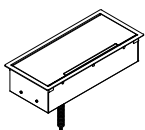

.....1 X PCS91/U1HW



.....2 X Mounting Bracket



.....4 X Thumb screw