

NOTE:

- Wireless output is 5W Max.
- Table thickness is 9.50mm (3/8") MIN. to 50.50mm (2") MAX.
- Mobile device must be equipped with a wireless charging receiver (Wireless charging accessories not included.) Check mobile manufacturer for compatibility.
- Cord length is 3 ft.
- Power adapter dimension is 1-27/32" X 1-1/2" X 29/32".

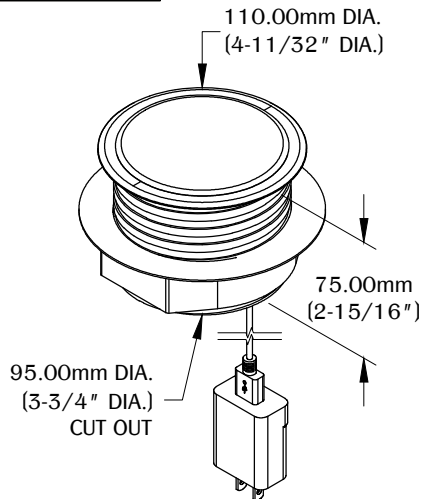

1

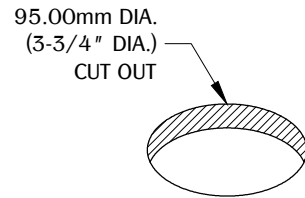

Determine the position and location of the unit on the work surface. Cut the hole at 95.00mm DIA. (3-3/4").

2

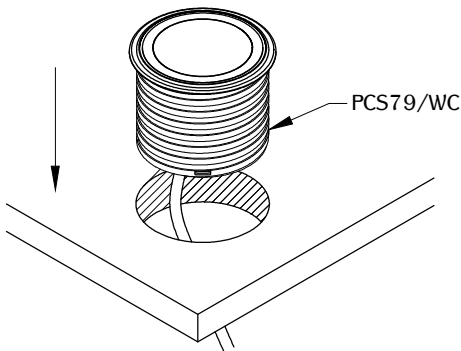

Remove the lock ring from the unit. Guide the cord through the cut out and install the unit. Make sure it is fully level on the surface.

3

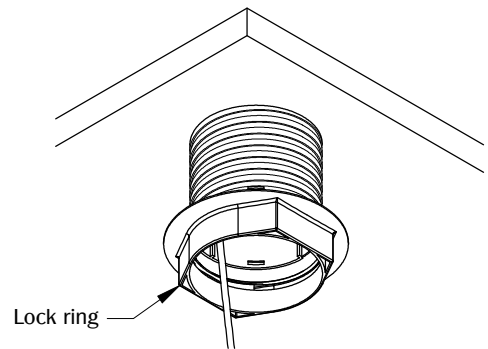

Guide the cord through the lock ring and secure the unit by tightening clockwise.

4

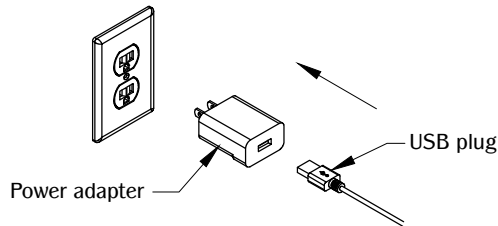

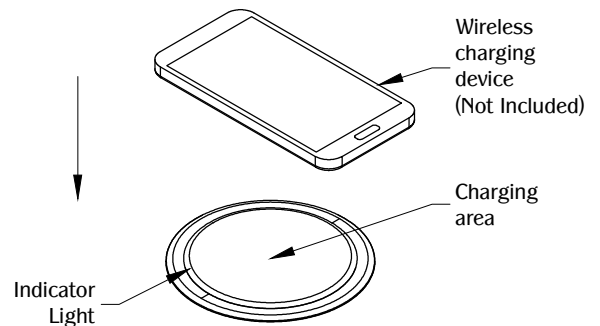

Plug in the USB plug from the unit to the power adapter. Plug the unit into nearby outlet (outlet should be close enough to where power cord is not taut or strained) and unit is ready for use.

5



Position the mobile device on the center of the charging area. The indicator light activates to signify that the device is actively charging or the charging icon will activate on the device's screen.

TABLE OF CONTENTS:

	..... 1x PCS79/WC
	..... 1x LOCK RING
	..... 1x POWER ADAPTER

CAUTION:

1. To reduce the risk of electric shock use only indoors.
2. Risk of electric shock. Do not plug into another relocatable power tap.