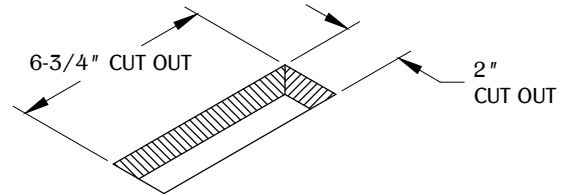

Table thickness is 3/4" MIN. to 1-3/4" MAX.

1



Determine the position and location of the unit on the work surface. Cut the hole at 6-3/4" X 2".

2

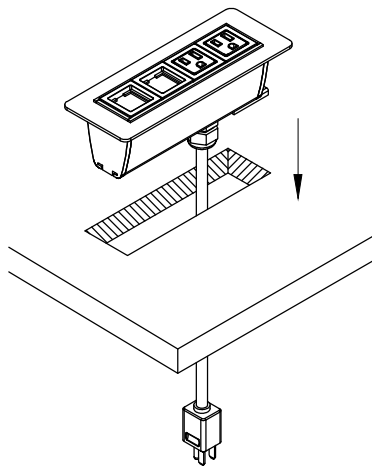

Drop the unit into the cut out. Make sure the unit is fully leveled into the work surface.

3

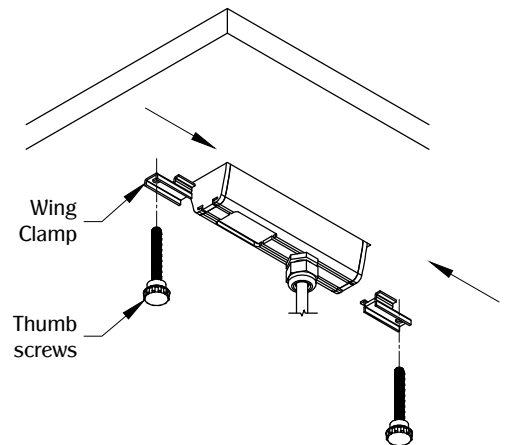



Slide the wing clamps in the underside track of the unit. Use (2) thumb screws secure the part in the work surface.

**NOTE:**

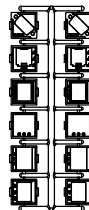
PLEASE USE APPLICABLE ADAPTER FROM DATA TREE. (SEE PCS DATA TREE PAGE FOR MORE INFORMATION.)

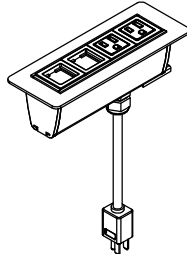
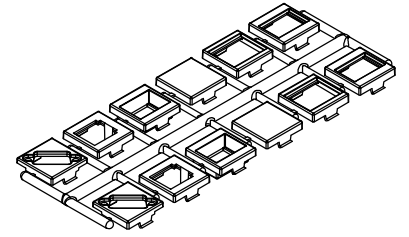

**TABLE OF CONTENTS:**

	.....1 X PCS49A-U (2 POWER & 2 DATA)
	.....2 X THUMB SCREW
	.....2 X WING CLAMP

## PCS Data Tree

- 1.) Select the appropriate adapter from the chart below. (example: Panduit Mini-Com Series jack would use "FFF" adapter marked on back of adapter.)



\*Jacks, not included, UL Listed (DUXR) or Recognized (DUXR2) jacks required.

Adapter	Manufacturer	Website
BBB	L-Com Keystone Modular	www.L-Com.com
BBB	NETCONNECT, and 110 Connect Series Modular Jack	www.Anixter.com
BBB	Siemon ZMAX Style	www.Siemon.com
BBB	Allen Tel Versa Tap Series	www.Graybar.com
BBB	Leviton Quick Port ® Series	www.Leviton.com
BBB	Belden REVConnect	www.Belden.com
BBB	HDMI Adapter Cable	www.Mockett.com
CCC	Hubbell Nextspeed™ Keystone Series	www.Hubbell-premise.com
CCC	ADC Truenet Series	www.Anixter.com
DDD	Blank (no coupler/jack)	-
EEE	Ortronics TracJack Series	www.Ortronics.com
FFF	Panduit Mini-Com Series	www.Panduit.com
HHH	Video Monitor Jack/DB-15, panel mount solder style	www.Mockett.com

- 2.) Snap Jack into adapter following the instructions provided with the jack.
- 3.) Once assembled, snap adapter into the notched, square holes in the orientation shown.

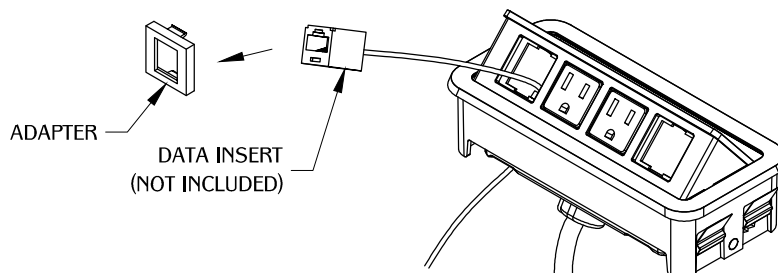

**NOTE:** Please verify fit of jack in adapter before ordering large quantities as manufacturer designs may change without notice.