

PART #

PCS36/2/A/2E

310.318.2491 • 800.523.1269 • www.mockett.com

NOTE:
Please **DO NOT**
remove tape!

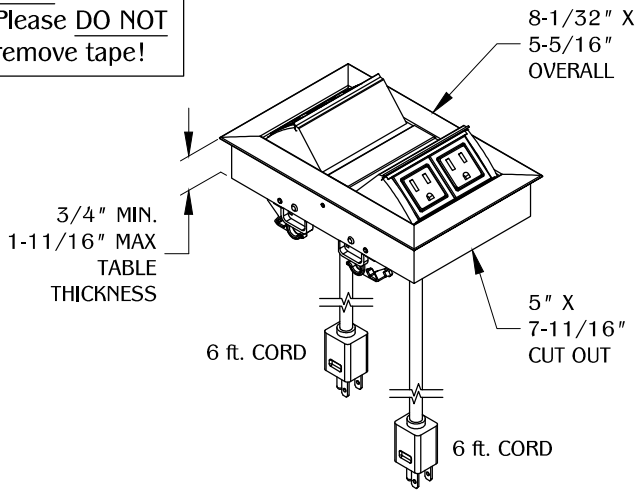

1

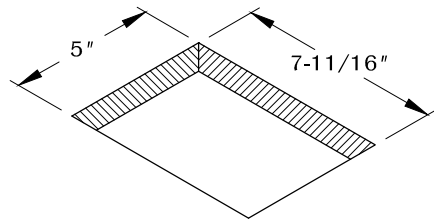

Determine the position and location of the unit on the work surface. Cut the hole at 5" X 7-11/16".

2

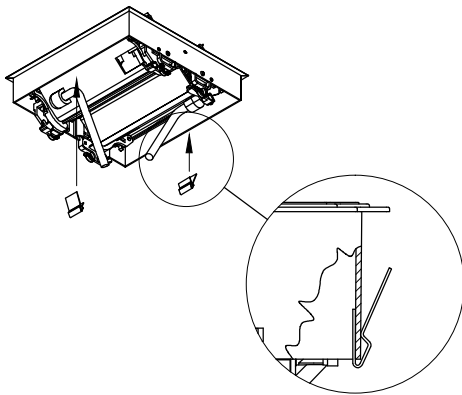

Place metal clips near the front and back of the unit. (**NOTE:** Metal clips are for use in hard surface material only as an optional mounting means.)

3

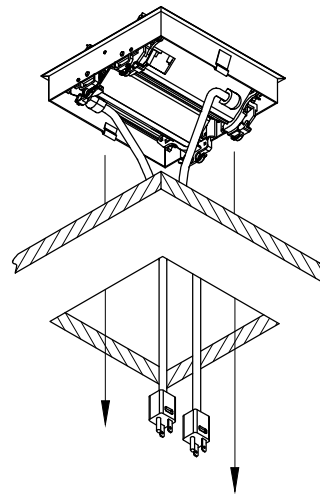

Drop in unit into cut out.

4

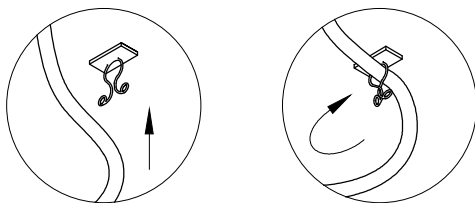

Optional wire manager.

5

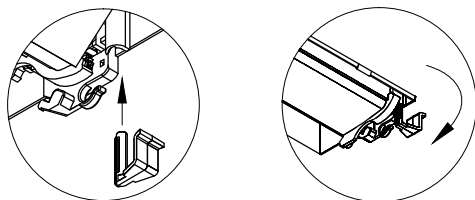

Secure unit by turning bottom wing clamp.

TABLE OF CONTENTS:

 1 X PCS36/2/A/2E (4 POWER)
 2 X WIRE MANAGER
 2 X METAL CLIPS
 2 X WING CLAMP