

WEIGHT CAPACITY: 75 LBS PER LEG

1

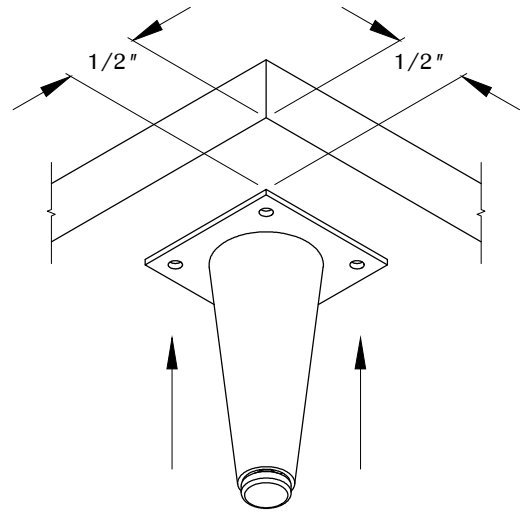

NOTE: 1/2" OFFSET FROM CORNER RECOMMENDED.

2

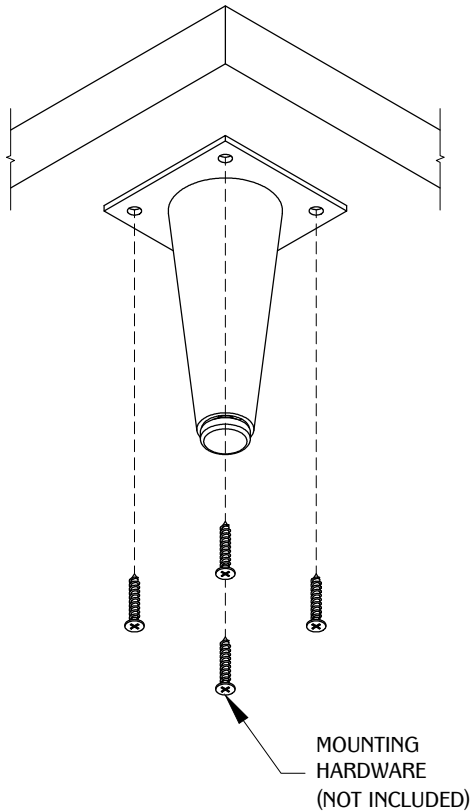

3

