

PART #

DP288

310.318.2491 • 800.523.1269 • www.mockett.com

NOTE:

- Front drawer panel thickness is 3/4" MAX.
- All dimensions have a +/- 1/32" tolerance. we do not recommend drilling or cutting any holes before receiving a product or a product sample.

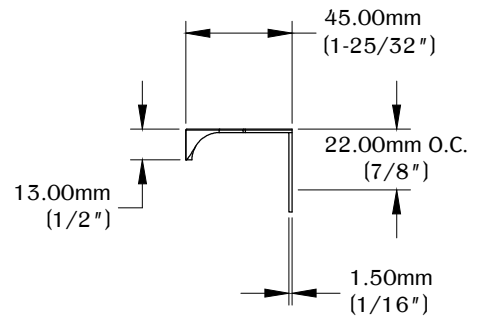
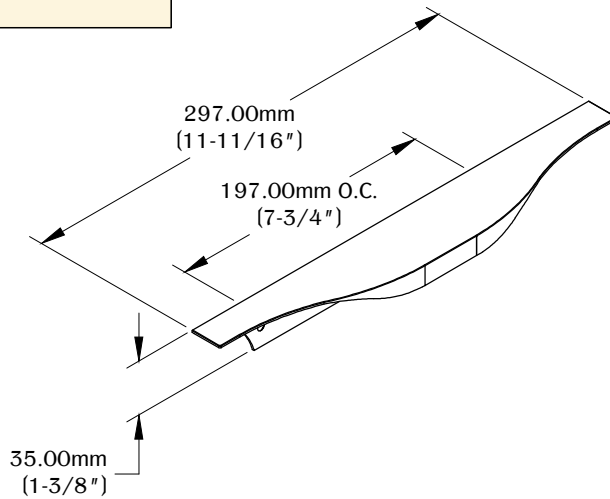

RIGHT VIEW

1 SURFACE MOUNT

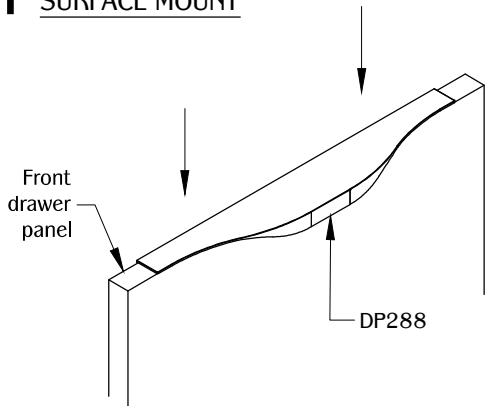

Determine the position and location of the part in the work surface. Center the part on top of the front drawer panel. (Skip to STEP # 3.)

2a FLUSH MOUNT

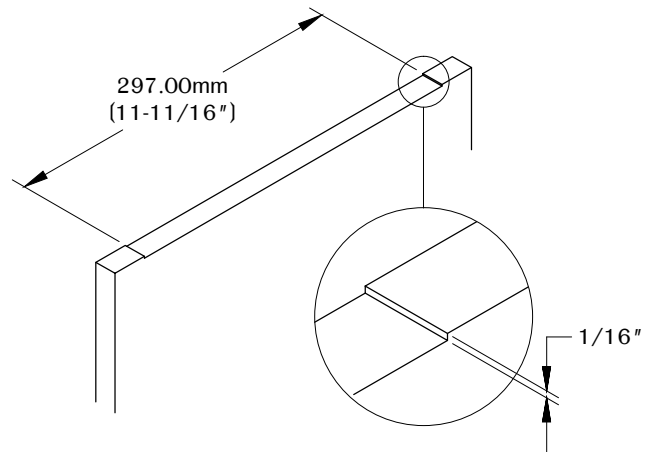

Route the top of the work surface.

2b

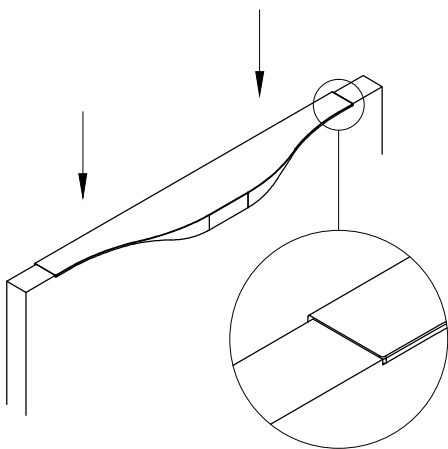

Install the part flushed in to the routed surface.

3

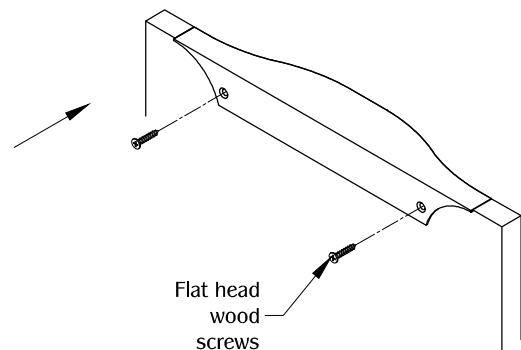

Use (2) mounting screws to secure the part in to the work surface. Make sure the part is fully level on the work surface.

TABLE OF CONTENTS:



..... 1X DP288



..... 2X 1/2" Flathead wood screws