

1

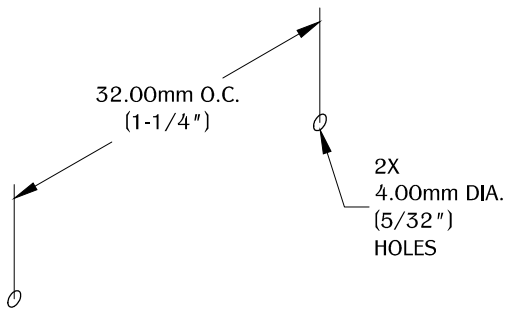

2

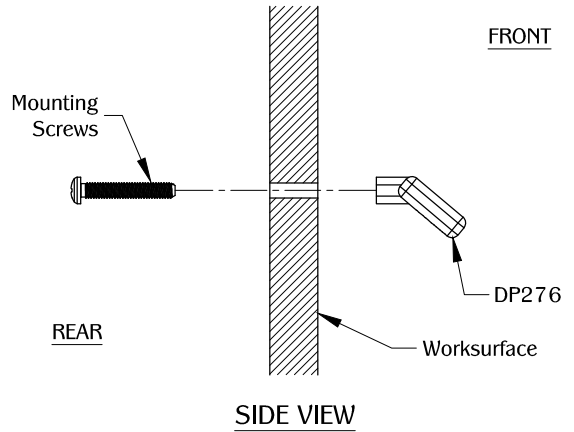



Determine the position and location of the part in the work surface. Mark the mounting positions and drill the pilot holes for the mounting hardware.

Use (2) screws to secure the part in to the work surface. Make sure the part is fully level on the work surface.

NOTE:

- Mounting screw lengths available upon request.
- All dimensions have a $\pm 1/32$ " tolerance. We do not recommend drilling or cutting any holes before receiving a product or a product sample.

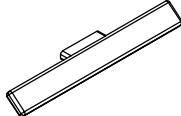
TABLE OF CONTENTS:

1X DP276
2X 1" 4mm-70 thread Machine screws