

PART #

DP224

310.318.2491 • 800.523.1269 • www.mockett.com

NOTE: Recommended to be installed by a professional woodworker.

1a Option A

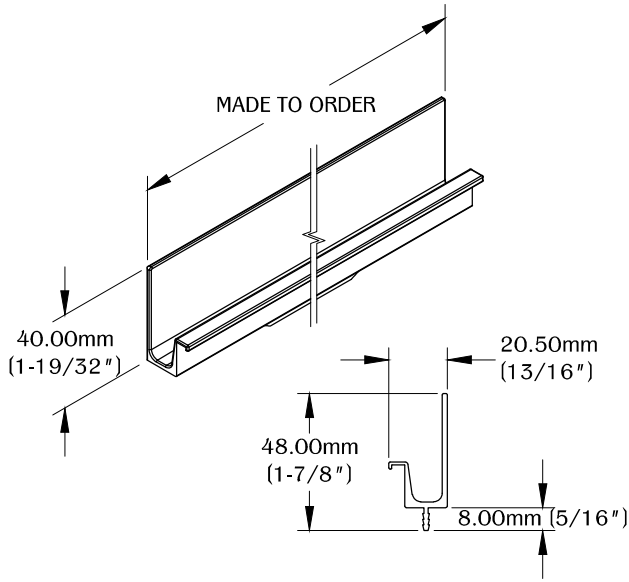

RIGHT VIEW

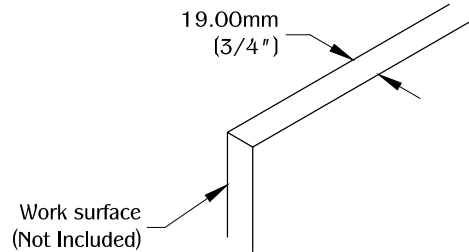

Determine the position and location of the unit to install flush on the work surface. Make sure the thickness is 19.00mm (3/4").

2a

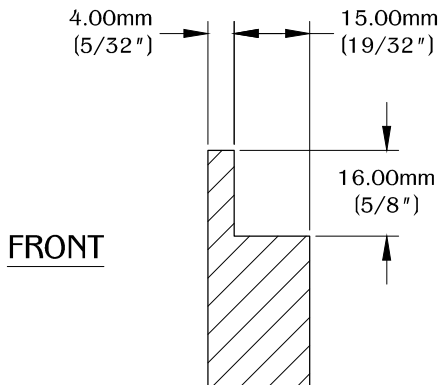

Route the top of the work surface.

3a

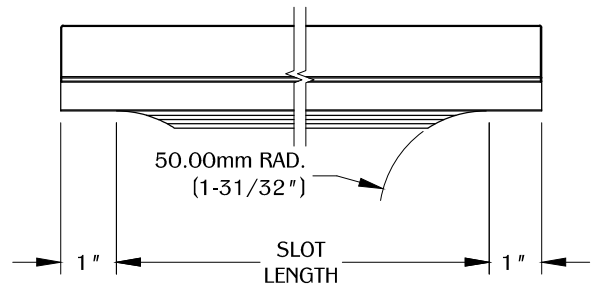

Determine the slot length for the part.

4a

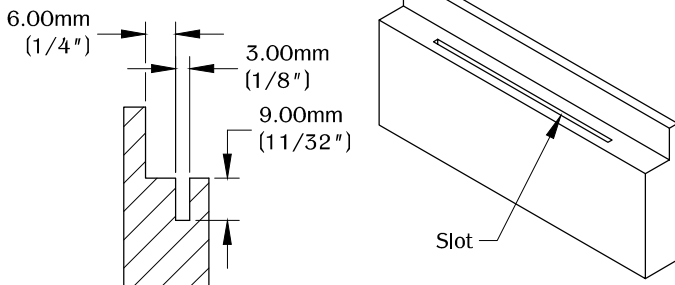

SIDE VIEW

Route the slot length and depth on the top of the work surface.

5a

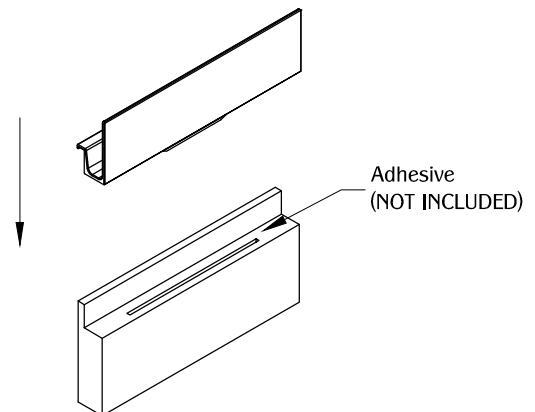

Install the part and make sure it is fully leveled into the work surface. (Note: Apply adhesive for a secure installation.)

1b Option B

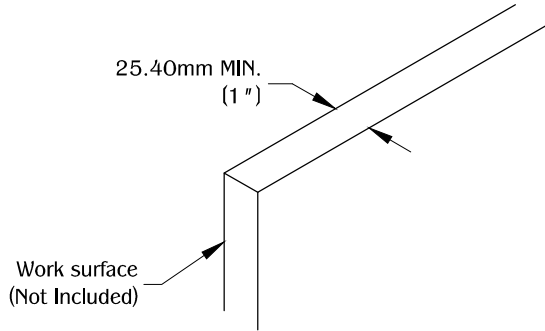

Determine the position and location of the part to install flush on the work surface. Make sure the thickness is 25.40mm (1") MIN.

2b

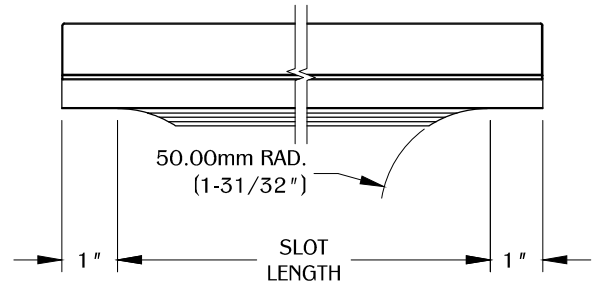

Determine the slot length for the part.

3b

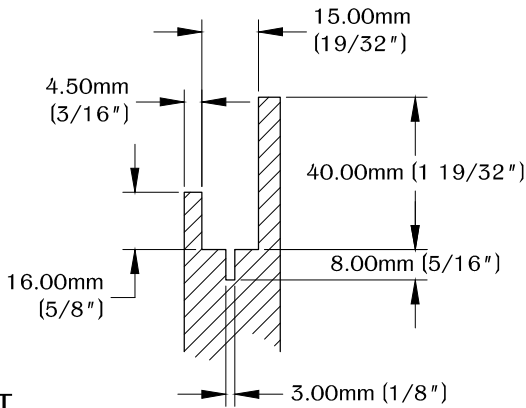

FRONT

Determine the front of the work surface. Follow and route the top of the drawer panel as shown above.

4b

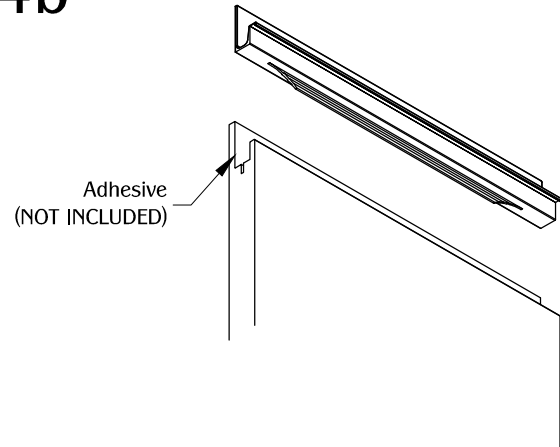

Install the part and make sure it is fully leveled into the work surface. (Note: Apply adhesive for a secure installation.)