

1

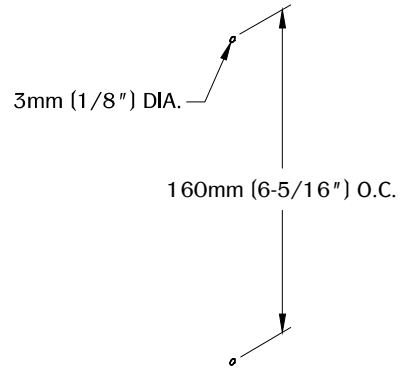

Determine the position and location of the DH7A/BB at the work surface. Drill a 3mm (1/8") diameter hole with the recommended on center dimension.

2

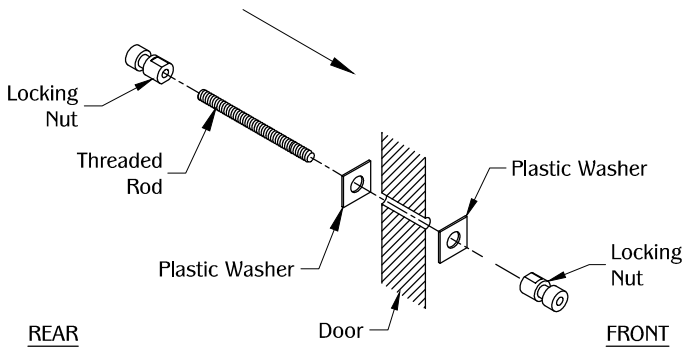





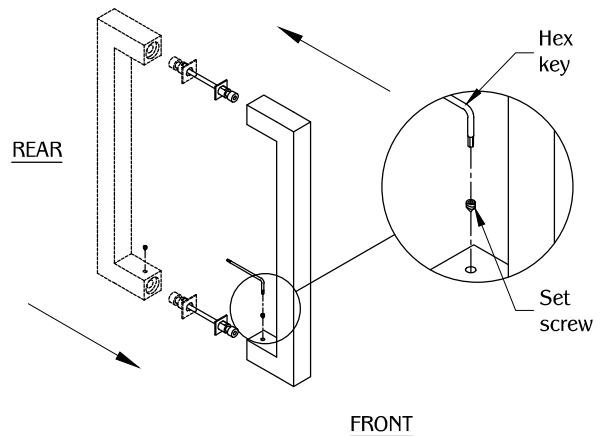

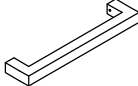

Assemble the base with (1) locking nut, (1) threaded rod, and (1) plastic washer at the back of the work surface. Align the assembly through the predrilled hole. Repeat the same assembly order from the front side. (Note: Use the 63mm (2-1/2") threaded rod for thicker door.)

3



Align the DH7A/BB to the assembled base. Secure it with the (4) set screw using the hex key.

TABLE OF CONTENTS:

2 X DH7A/BB
2 X 4" Threaded rod
4 X Screw
4 X Wood Screw
4 X Locking Nut
8 X Plastic Washer
2 X Hex Key
4 X Set screw