

1

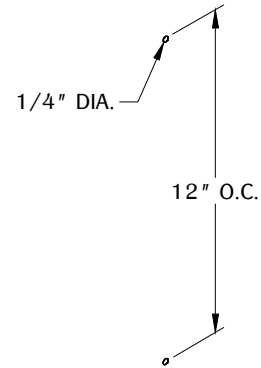

Determine the position and location of the DH3 at the work surface. Drill a 1/4" diameter hole with the recommended on center dimension.

2

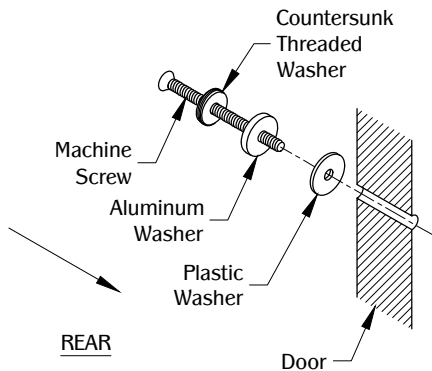

Assemble (1) machine screw, (1) countersunk threaded washer, (1) aluminum washer and (1) plastic washer at the back of the work surface. Align the assembly through the predrilled hole. (Note: Use 4" screw for thicker door.)

3

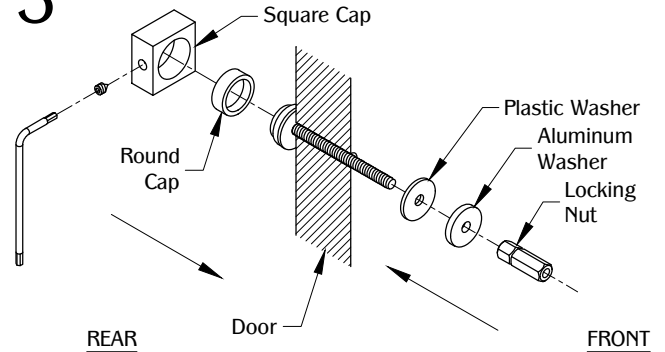

Assemble (1) plastic washer, (1) aluminum washer and (1) locking nut at the front of the work surface. Tighten the assembly. Finish the hardware assembly by installing the round and square cap. Repeat Step 3 & 4 for the other side.

4

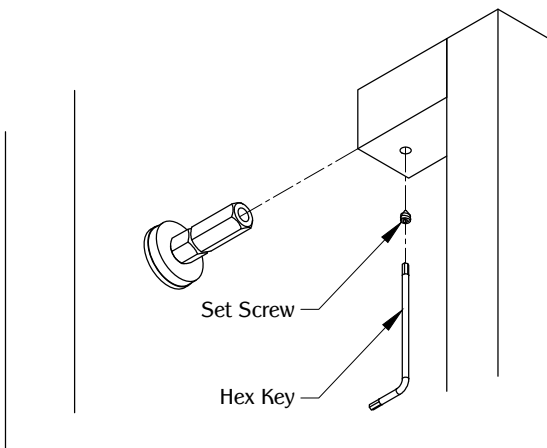

Align the DH3 to the assembled base. Secure it with the (2) set screw using the hex key.

TABLE OF CONTENTS:

1 X DH3
2 X Square Cap
2 X Round Cap
2 X 1-3/4" Machine screw
2 X 4" Machine screw
4 X Aluminum Washer
2 X Locking Nut
4 X Plastic Washer
2 X Countersunk Threaded Washer
1 X Hex Key
4 X Set screw