

1

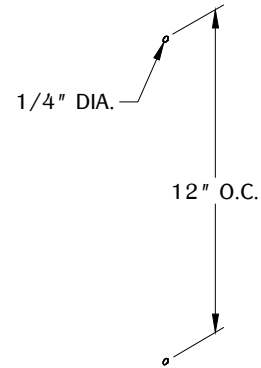

Determine the position and location of the DH3 at the work surface. Drill a 1/4" diameter hole with the recommended on center dimension.

2

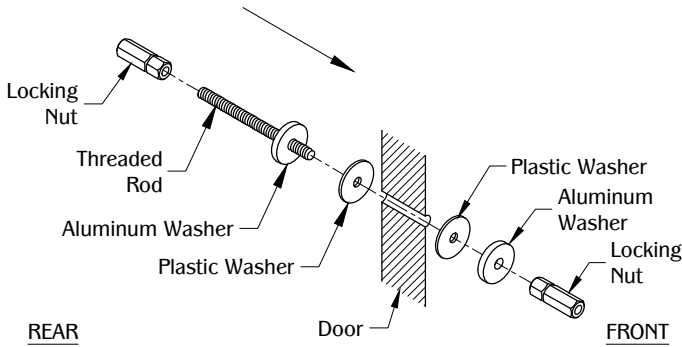

Assemble the base with (1) locking nut, (1) threaded rod, (1) aluminum washer and (1) plastic washer at the back of the work surface. Align the assembly through the predrilled hole. Repeat the same assembly order from the front side.

3

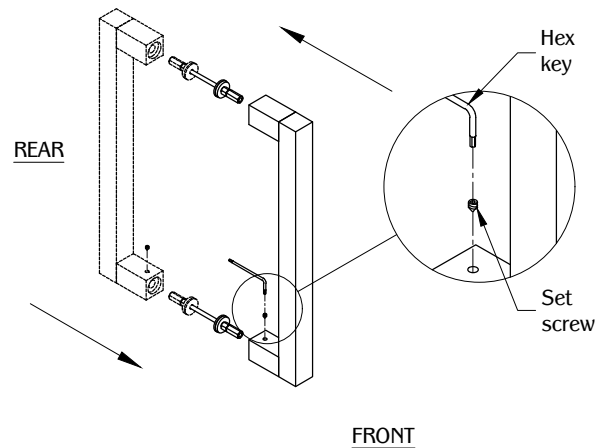

Align the DH3 to the assembled base. Secure it with the (4) set screw using the hex key.

TABLE OF CONTENTS:

2 X DH3
2 X 2-1/2" Threaded rod
4 X Aluminum Washer
4 X Locking Nut
4 X Plastic Washer
1 X Hex Key
4 X Set screw