

DG-BE

310.318.2491 - 800.523.1269 - [www.mockett.com](http://www.mockett.com)

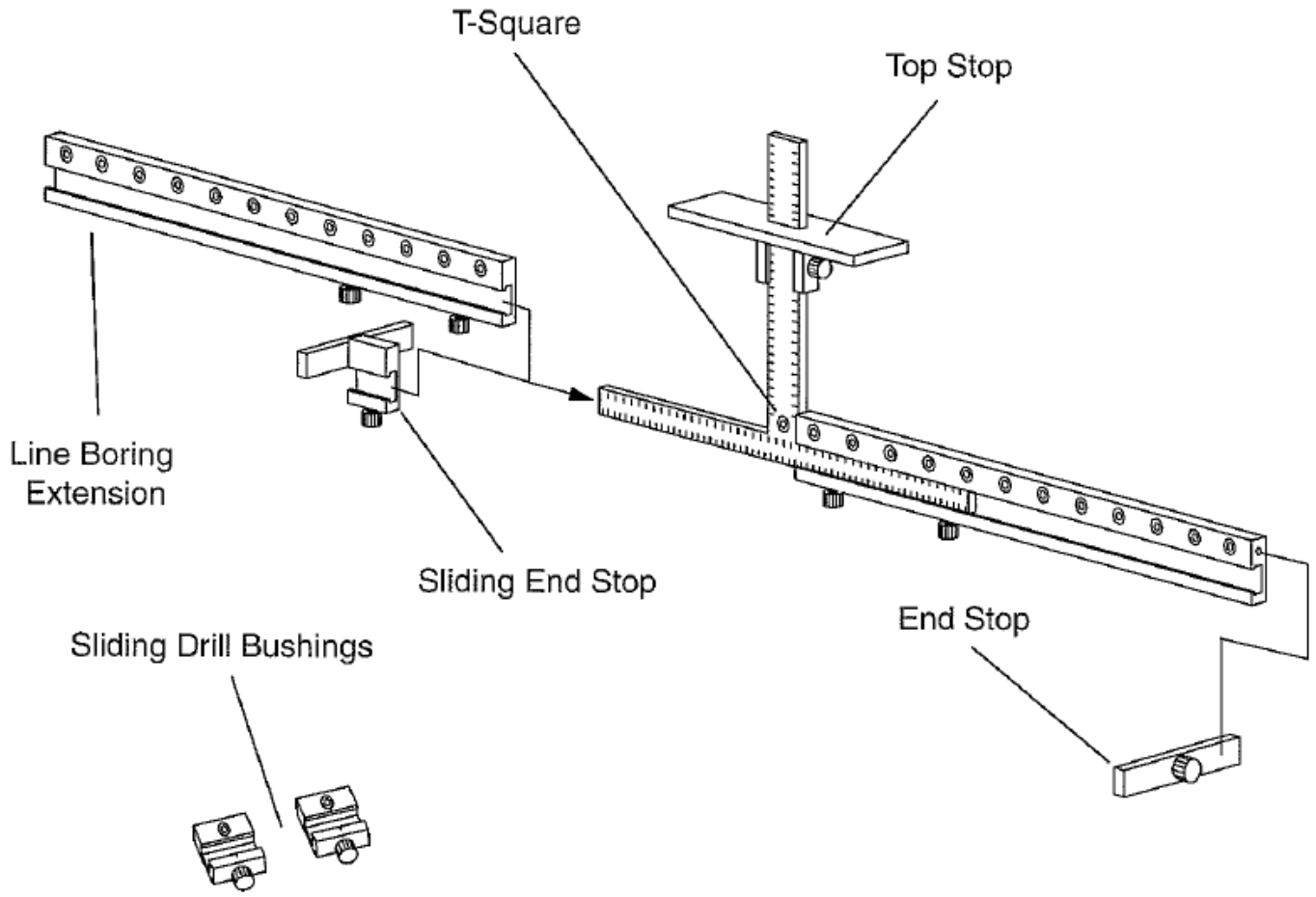

PATENT 5,807,036

MADE IN USA

# Door Hardware

1

Adjust handle spacing

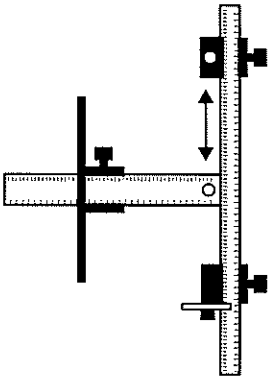

2

Adjust distance from edge and top / bottom of door

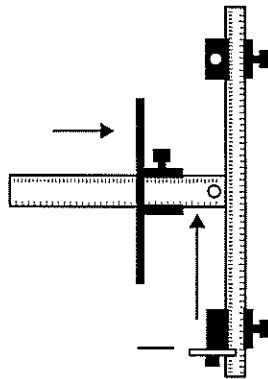

\*For Closer Layouts\*

Flip top stop upside-down to drill closer to edge.

Flip sliding end stop upside down to drill closer to bottom or top

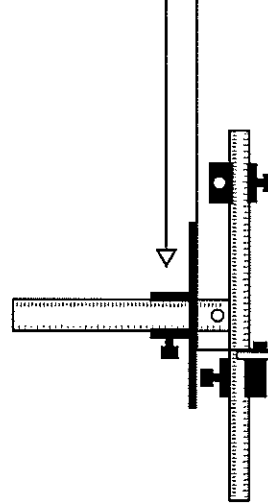

3

Set on door, hold in place while drilling

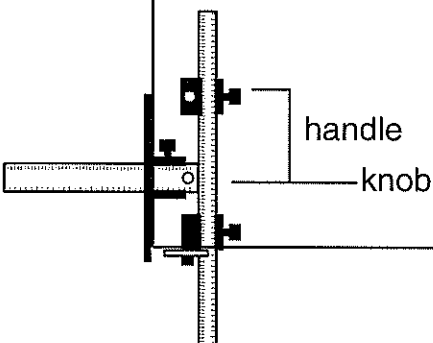

4

Opposite Door

Flip tool over on opposite door. Repeat step 3

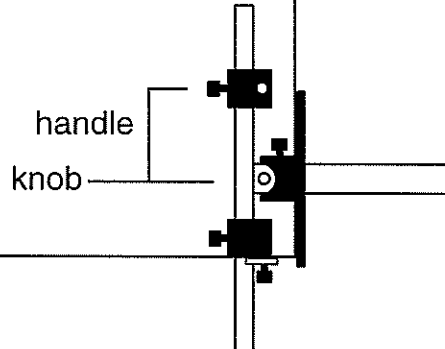

# Tall Door Hardware

For faster installation, use **The Faster Method** described in Drawer Front Hardware

①

## Handles

Set each sliding bushing at half the total length of hardware.

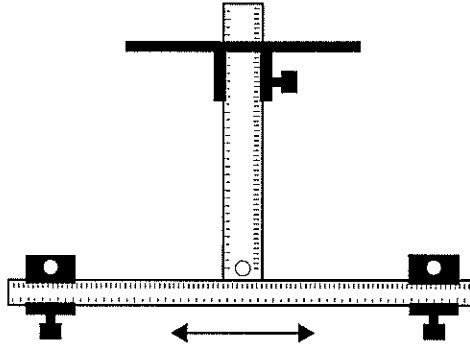

## \*Knobs

Leave sliding guides on for stability, use T - square bushing to drill.

②

Set top stop at desired location from edge of door.

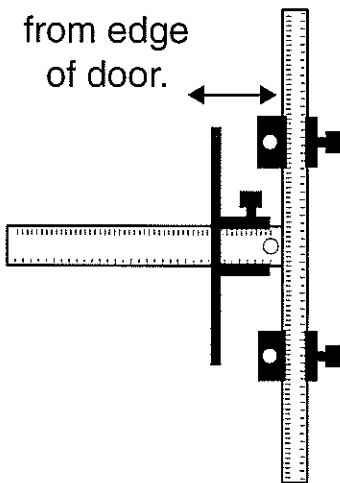

③

Mark center line on door.

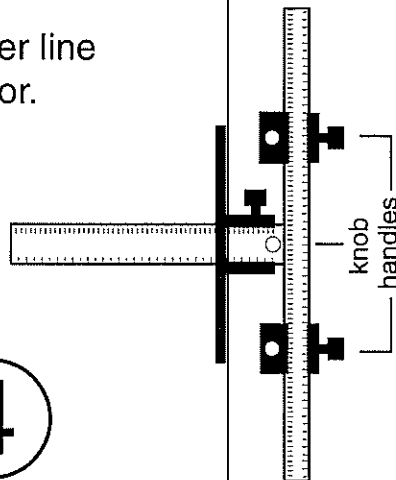

④

Align top stop notches with center line. Hold in place and drill.

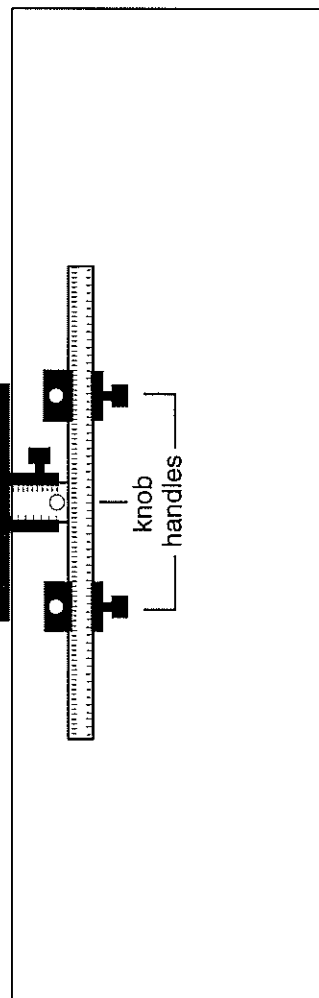

Side View

# Drawer Front Hardware

## The Faster Method

This method eliminates the need to mark a centerline.  
It is especially an advantage when drilling  
a series of drawers the same width.

1

Set for desired spacing  
and height of  
hardware

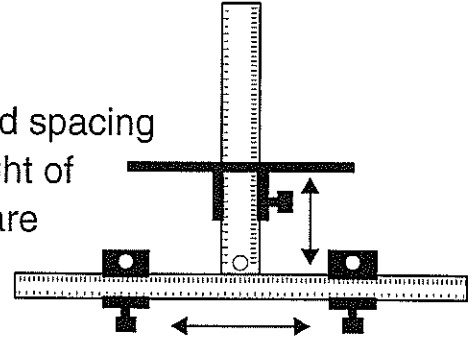

2

Flush end of T - square  
with edge of drawer front

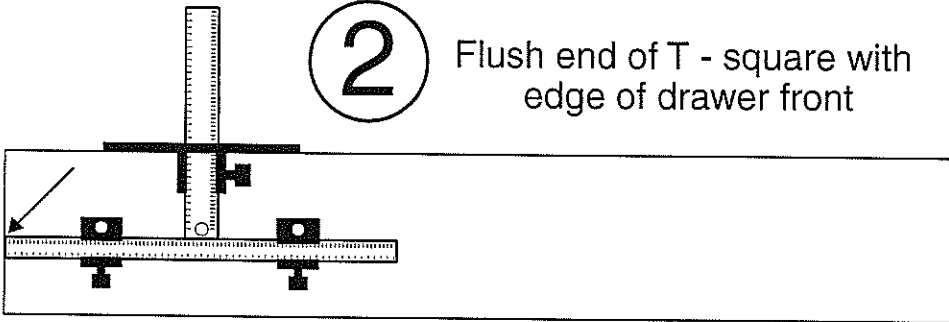

3

Measure distance from edge of  
T - square to end of drawer front

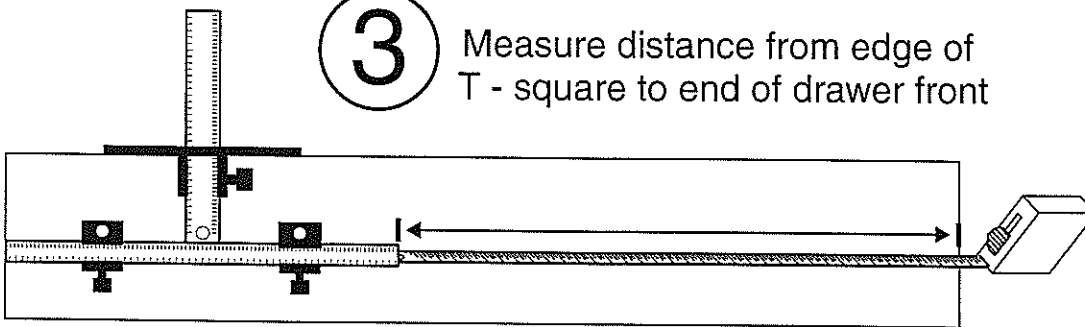

4

Divide distance in half while  
holding tape measure againsts tool.  
The tool will now be on center.  
Hold in place and drill

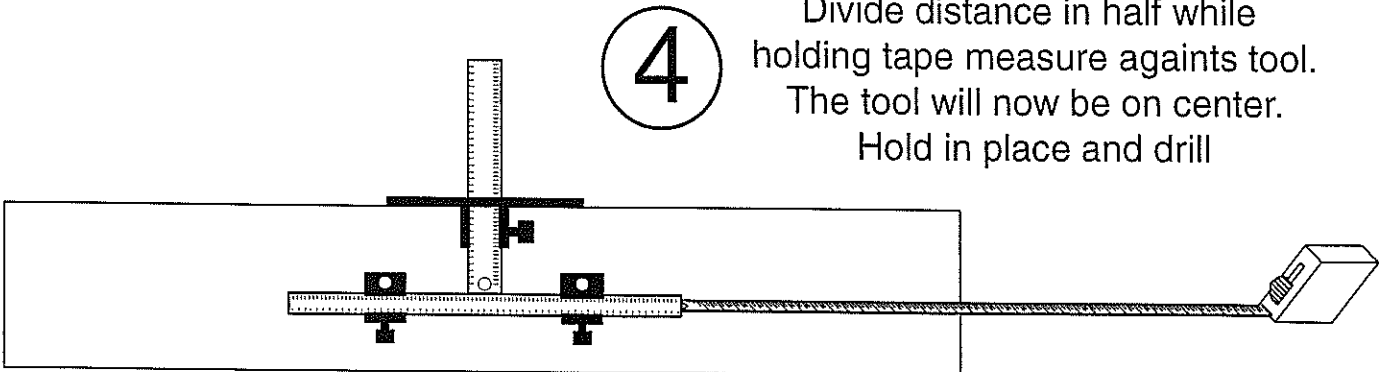

# Drawer Front Hardware

## The Traditional Method

1

### Handles

Set each sliding bushing at half the total length of hardware.

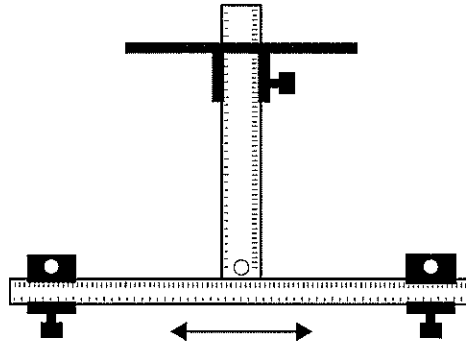

### \*Knobs

Leave sliding guides on for stability, T-square bushing will be used to drill.

2

Set top stop at 1/2 the distance of drawer height or desired placement.

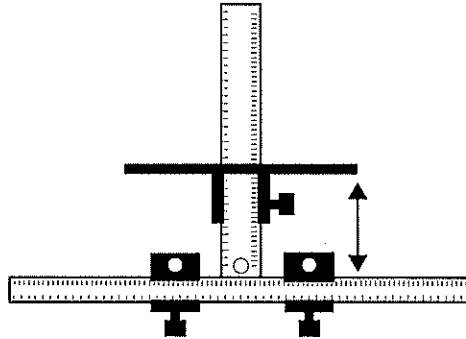

3

Draw center line on drawer front.  
Align top stop notches with center line.  
Hold in place and drill.

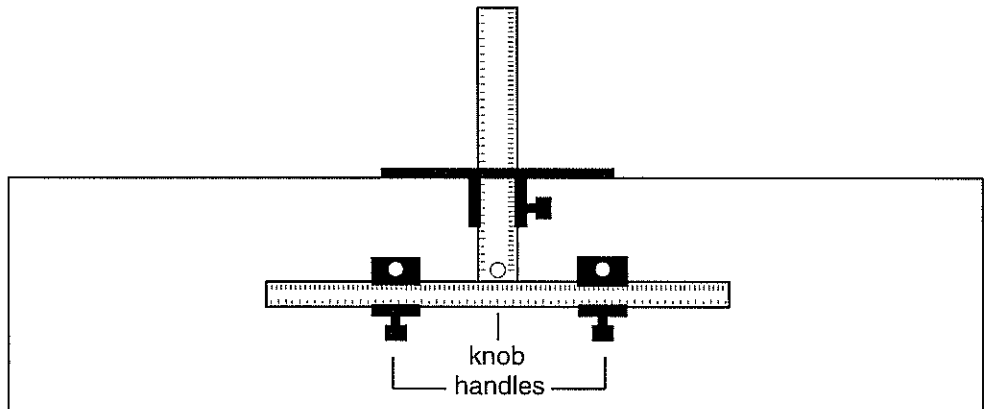

Top view

# Line Boring

Before Cabinet Assembly

## Front Holes

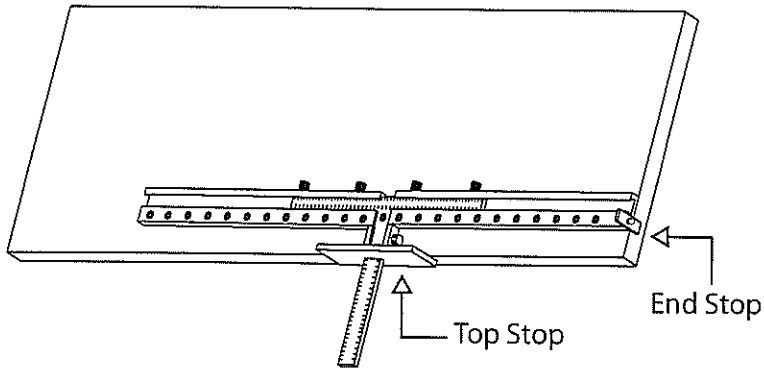

1 Place the top stop against bottom of panel and end against edge of panel.

2 Clamp & drill.

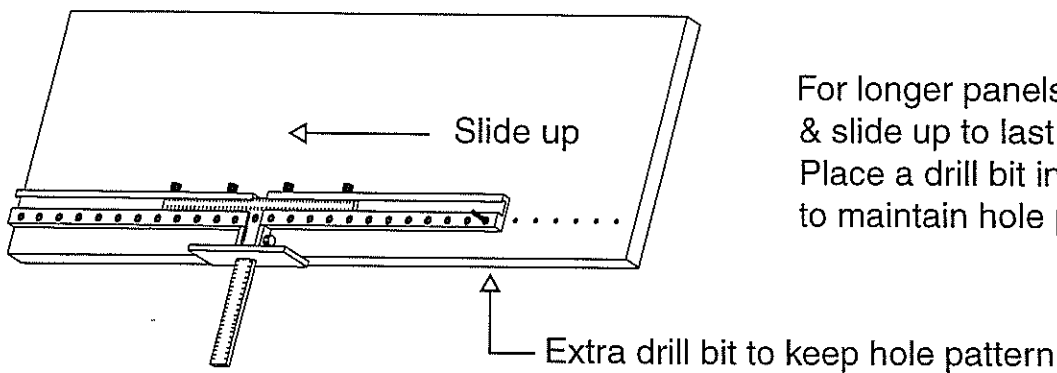

For longer panels, remove end stop & slide up to last hole drilled. Place a drill bit in last hole drilled to maintain hole pattern.

## Back Holes

1 Flip drill guide to back of panel.

2 Place the top stop against top of panel and extension end stop is against edge of panel.

3 Clamp & drill.

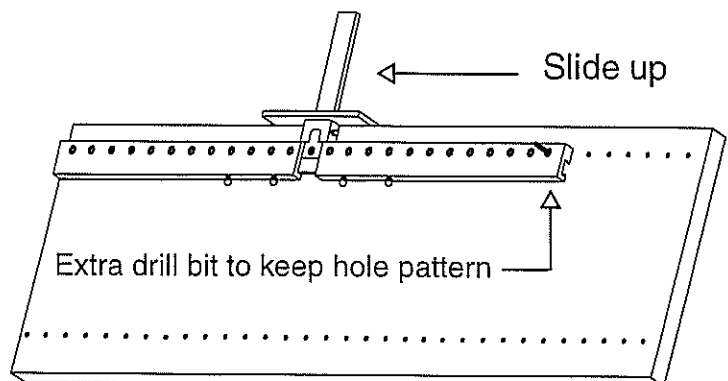
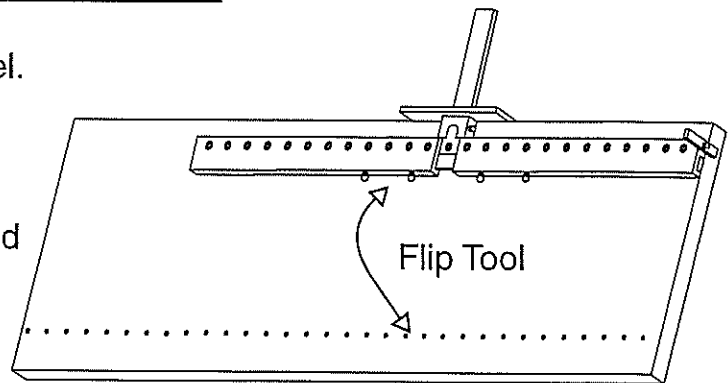

For longer panels, remove end stop & slide up to last hole drilled. Place a drill bit in last hole drilled to maintain hole pattern.

# Line Boring

After Cabinet Assembly

## Front Holes

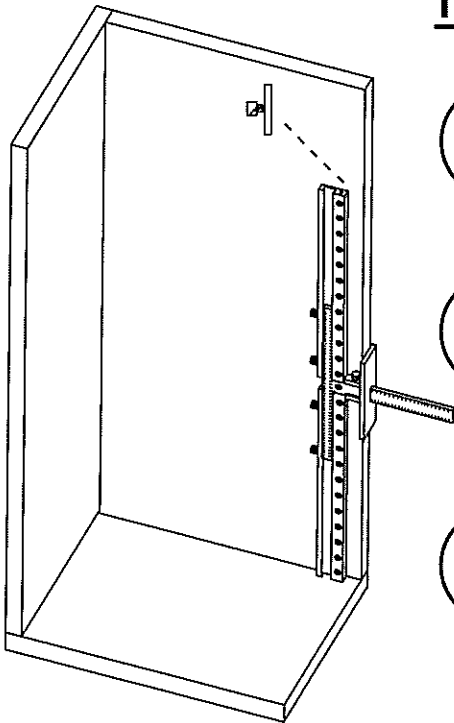

- 1 Remove End Stop
- 2 Set drill guide top stop against front of cabinet and bottom extension on bottom on cabinet.
- 3 Secure with 2 clamps - drill desired holes.

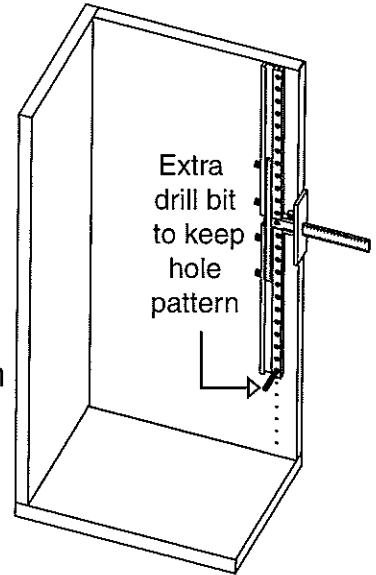

## Back Holes

- 1 Remove Top Stop.

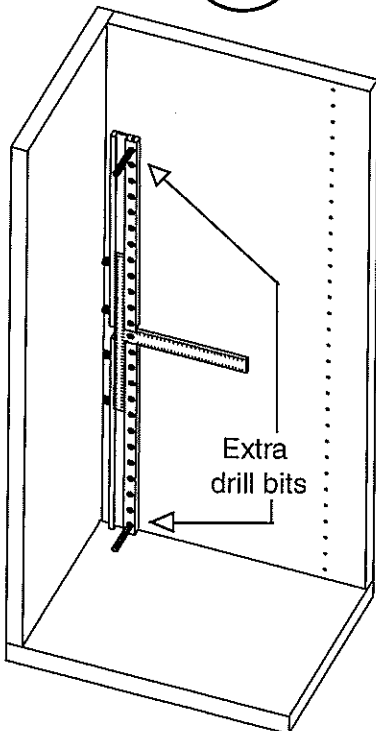

- 2 Place drill in back of cabinet. Press thumbscrews against the back of cabinet and the drilling extension against bottom of cabinet.
- 3 Hold against the back panel and drill first hole at the bottom, then second hole at the top.
- 4 Place extra drill bits in top and bottom holes to stabilize drill guide, drill remaining holes.

For longer panels, slide drill guide up and place drill bit in last hole drilled to maintain drilling pattern.

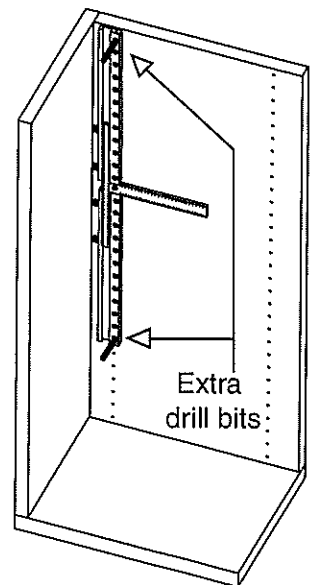

# Oversized Hardware

For hardware spacing 12 inches and above, use optional line boring extensions to install. Handles above 6 inches are made in 32MM increments, even if they are labeled imperial center to center (CC). Be sure to line up the holes of the hardware with the corresponding bushings AND count the bushings on each side to verify the hardware will be centered.

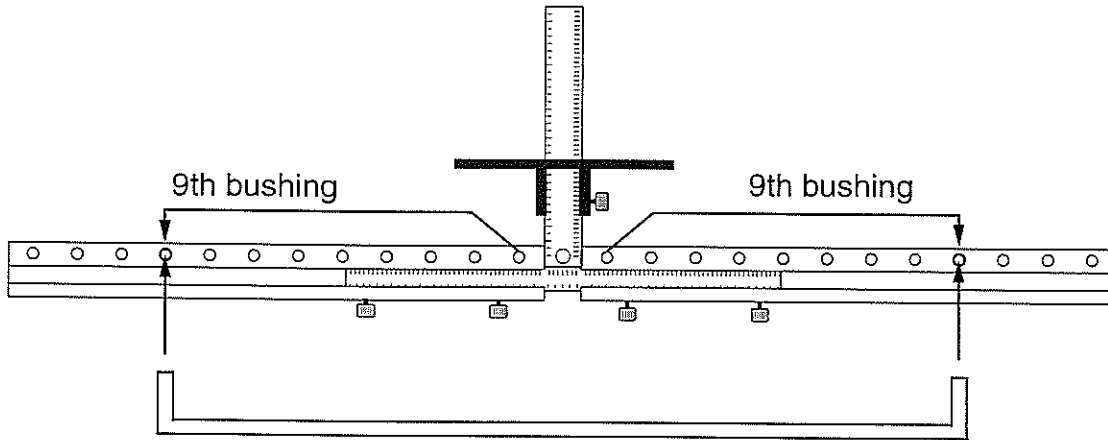

Typically, hardware will line up as shown above with equal bushing spacing.

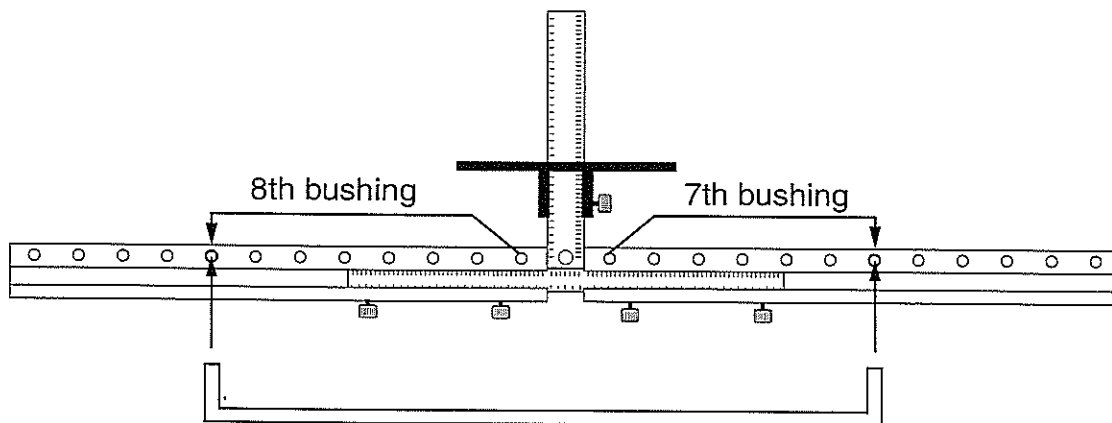

Some hardware will lineup on an uneven placement of bushings. To correct, simply move EACH extension 16mm away from T square.

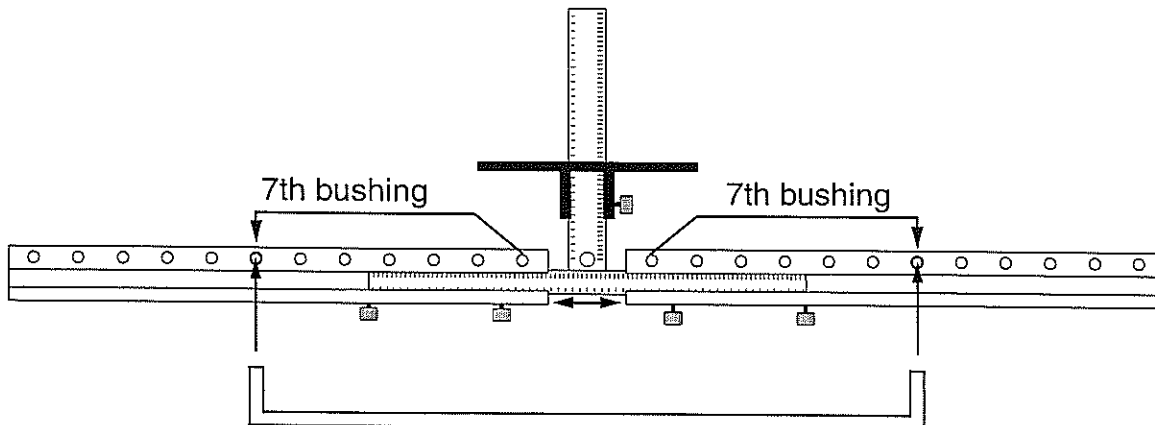

After moving each extension bar an equal amount, confirm that the handle is evenly spaced on each side of tool and the holes line up with bushings. Once hardware spacing is confirmed, place tool on door or drawer and drill.



## Manufacturers Limited One Year Warranty:

Precision Casewerk makes every effort to assure that its products meet high quality and durability standards.

We warranty to the original purchaser that this product is free from defects in material and workmanship for the period of 1 year from the date of purchase.

This warranty does not apply to damage due directly or indirectly to alteration, misuse, abuse, negligence or accidental, or repairs outside our facilities, lack of maintenance, or normal wear and tear.

We shall in no event be liable for death, injuries to persons or property, or for incidental, contingent, special or consequential damages arising from the use of our product.

Some states do not allow the exclusion or limitation of incidental or consequential damages.

So the above limitations may not apply to you.

To take advantage of this warranty, the product or part must be returned to us with the transportation charges prepaid. Proof of purchase date and an explanation of the complaint must accompany the merchandise. If our inspection verifies the defect, we will either repair or replace the product at our election.

We will return repaired products at our expense, but if we determine there is no defect, or that the defect resulted from causes not within the scope of our warranty, then you must bear the cost of returning the product.

Subject to proof of purchase. Only available to original owner.

This warranty gives you specific legal rights and you may also have other rights which vary from state to state.

## Bushing Limited Lifetime Warranty:

Our bushings are warrantied for the life of the product and available only to the original purchaser.

Precision Casewerk will offer standard replacement bushings for it's products. Upon RMA, replacement bushings will be sent to the reseller whom the product was purchased from or in approved cases,

directly to the customer. Upon RMA, Precision Casewerk may insert the bushings for the customer in special circumstances, freight will be paid by the customer.

This warranty does not apply to damage due directly or indirectly to alteration, misuse, abuse, negligence or accidental, or repairs outside our facilities, lack of maintenance.

Subject to proof of purchase.

Some states do not allow the exclusion or limitation of incidental or consequential damages.

So the above limitations may not apply to you.