

TOP VIEW

1a Undermount Installation

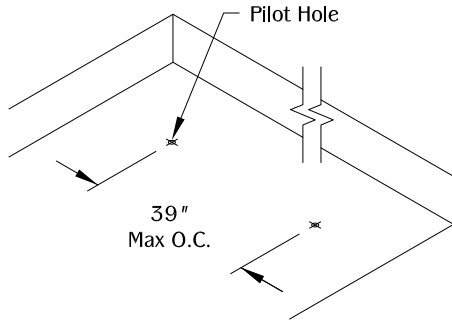

Determine the position and location of the wire manager under the work surface. Mark and drill pilot holes at 39" max on center. (Note: Pilot hole DIA. and depth will be determined by choice of mounting hardware. Hardware NOT INCLUDED.)

2a

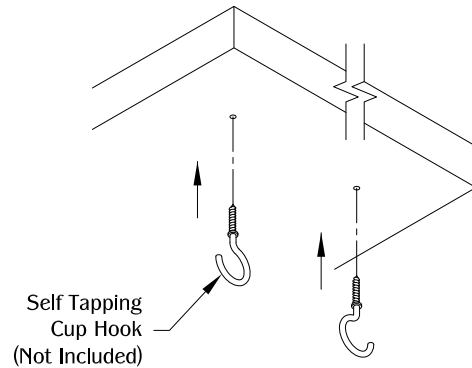

Hand tighten (2) self tapping cup hooks into the pilot holes. Make sure the hooks are fully level on the work surface.

3a

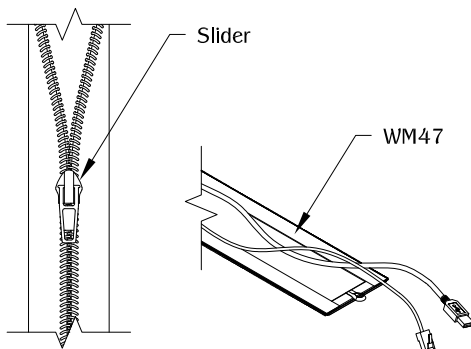

Use slider to unfasten wire manager so that wires may be placed inside. Refasten wire manager once all wires have been properly placed and organized.

4a

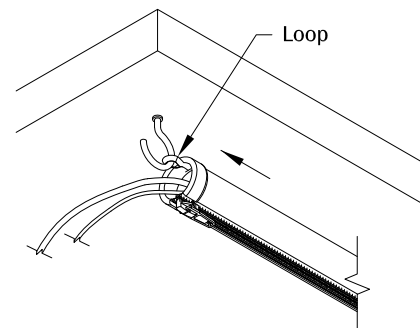

Use the loops on the ends of the wire manager to attach the wire manager to the hooks under the work surface.

1b Vertical Installation

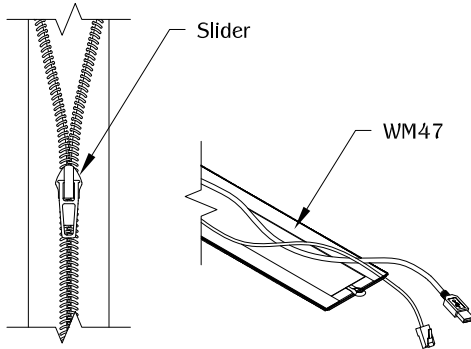

Use slider to unfasten wire manager so that wires may be placed inside. Refasten wire manager once all wires have been properly placed and organized.

2b

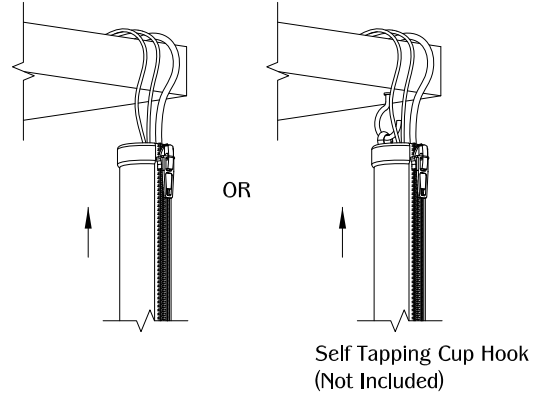

Place the wire manager in the desired position and location near the edge of the work surface. (Note: Install optional cup hook near the edge of the work surface and use the loop on the end of the wire manager to attach the wire manager to the hook.)