

WM24

PROPRIETARY AND CONFIDENTIAL.
ALL DIMENSIONS HAVE A +/- 1/32" TOLERANCE UNLESS OTHERWISE SPECIFIED. WE DO NOT RECOMMEND DRILLING OR CUTTING ANY HOLES BEFORE RECEIVING A PRODUCT OR A PRODUCT SAMPLE.

TABLE OF CONTENTS

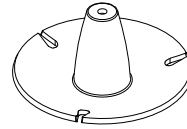

..... 1X WM24



..... 1X 3/4" No. 10
Wood Screw

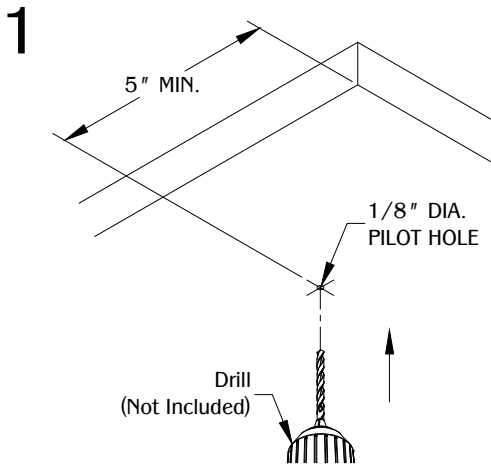
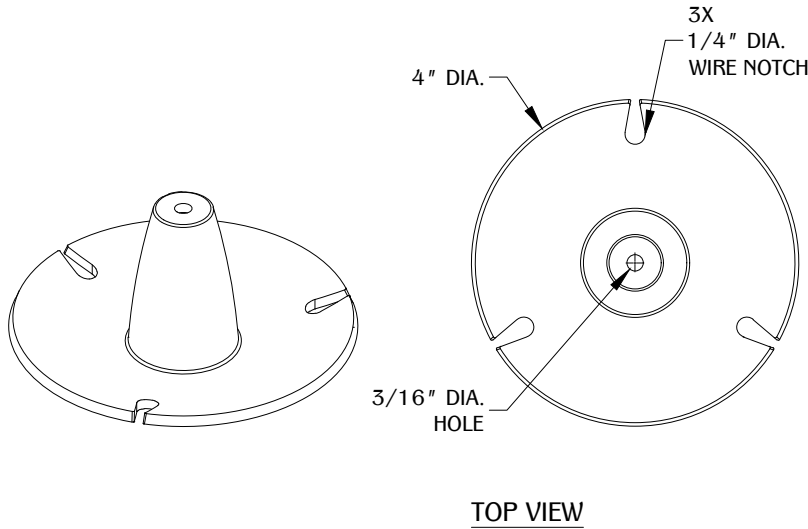

Determine the position and location of the part under the work surface. Allow 5" minimum clearance from the front edge for part to function. Mark the mounting position for the mounting hardware and drill a 1/8" DIA. pilot hole.

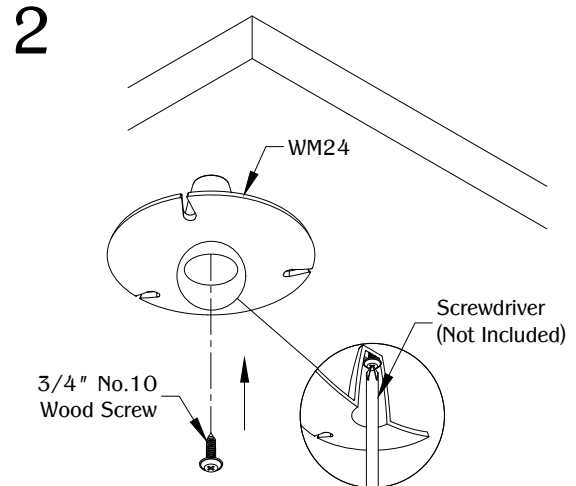

Align the WM24 to pilot hole and secure the 3/4" No. 10 wood screw with a screwdriver. Make sure part is fully level on the work surface.

WM24

PROPRIETARY AND CONFIDENTIAL.

ALL DIMENSIONS HAVE A +/- 1/32" TOLERANCE UNLESS OTHERWISE SPECIFIED. WE DO NOT RECOMMEND DRILLING OR CUTTING ANY HOLES BEFORE RECEIVING A PRODUCT OR A PRODUCT SAMPLE.

3

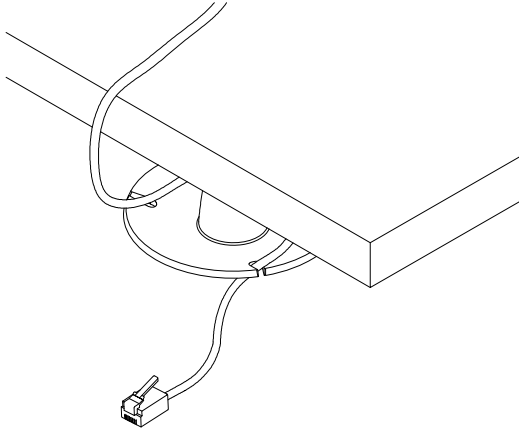

When firmly installed, wrap the excess cable around WM24, capturing the loose cable end by snapping it into any of the three notches.