

PCS61D/UC

PROPRIETARY AND CONFIDENTIAL.
ALL DIMENSIONS HAVE A +/- 1/16" TOLERANCE UNLESS OTHERWISE SPECIFIED. WE DO NOT RECOMMEND DRILLING OR CUTTING ANY HOLES BEFORE RECEIVING A PRODUCT OR A PRODUCT SAMPLE.





⚠ WARNING ⚠

- Plug into an appropriate outlet that is properly installed and grounded in accordance with all local codes and regulations.
- For indoor use only.
- For use on normally dry work surfaces only.
- If any malfunction occurs, do not attempt to disassemble or repair.
- Allow enough clearance for part operation and function.
- Avoid liquid spills into outlet.
- Do not insert foreign objects into power outlets or USB ports.
- Do not use provided screws on table thickness less than 1".
- Use caution not to pierce top surface with mounting screws.

SPECIFICATIONS

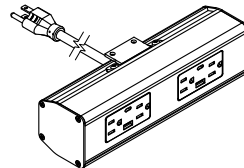
- 6 ft. cord length.
- USB-A & USB-C ports are for charging use only.
- For edge mounting, the recommended table thickness is 1" MIN. to 1-1/2" MAX.
- For under mounting, the recommended table thickness is 1" MAX.
- Overcurrent reset switch is located on the back of the unit.

TABLE OF CONTENTS

 1X PCS61D/UC
 1X Edge Mount Bracket
 1X Under Mount Plate
 2X 5/16" 8-32 Thread Flat-Head Machine Screw
 3X 3/4" No. 10 Button-Head Wood Screw

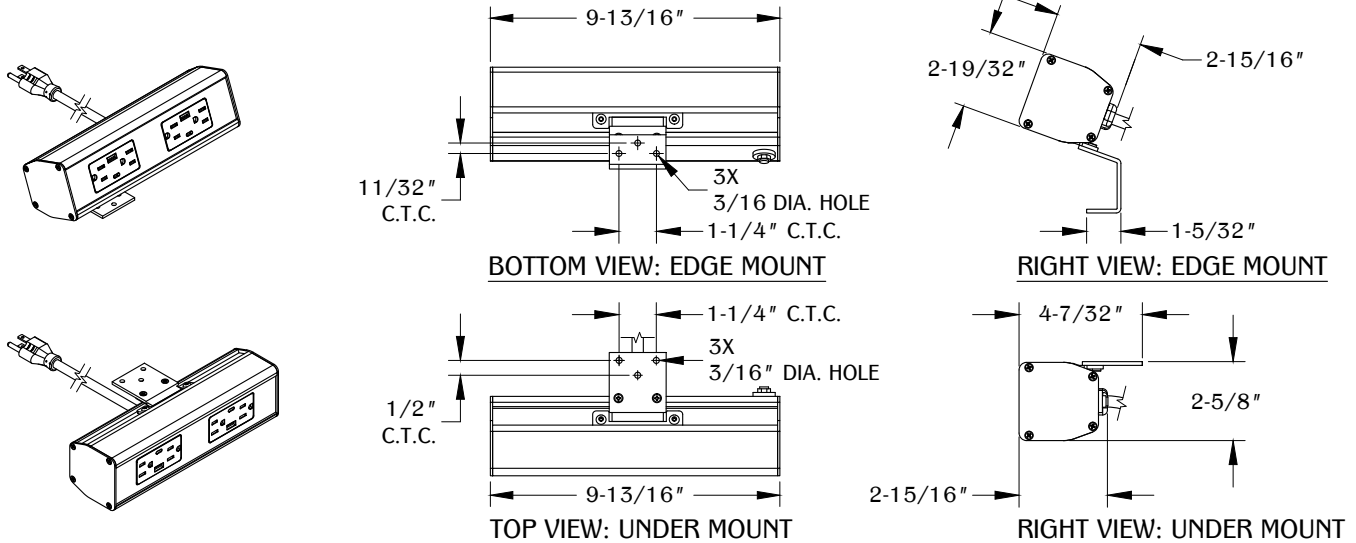

1 EDGE MOUNT

2

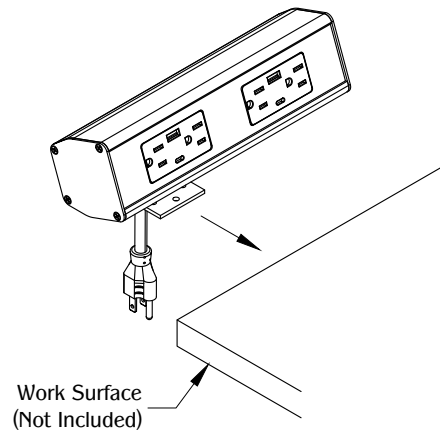
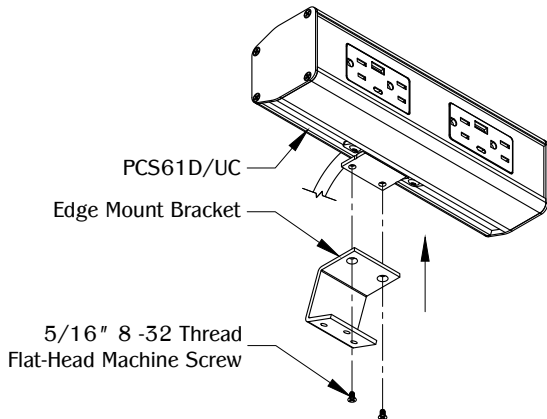

Attach the edge mount bracket to the unit by using (2) 5/16" 8-32 thread flat-head machine screw.

Determine position and location of the unit on the edge of the work surface. DO NOT place unit where cable is strained or trapped.

PCS61D/UC

PROPRIETARY AND CONFIDENTIAL.

ALL DIMENSIONS HAVE A +/- 1/16" TOLERANCE UNLESS OTHERWISE SPECIFIED. WE DO NOT RECOMMEND DRILLING OR CUTTING ANY HOLES BEFORE RECEIVING A PRODUCT OR A PRODUCT SAMPLE.

3

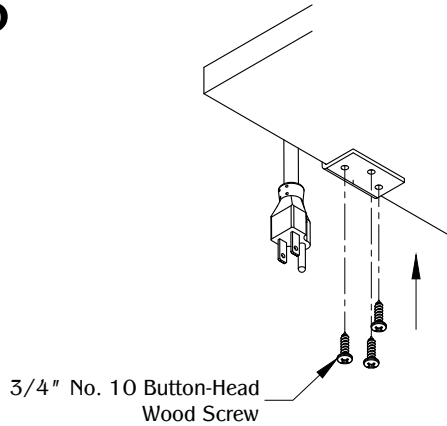

Secure the unit on the edge of the work surface by using (3) 3/4" No. 10 button-head wood screw. Plug into nearby outlet and unit is ready for use.

2

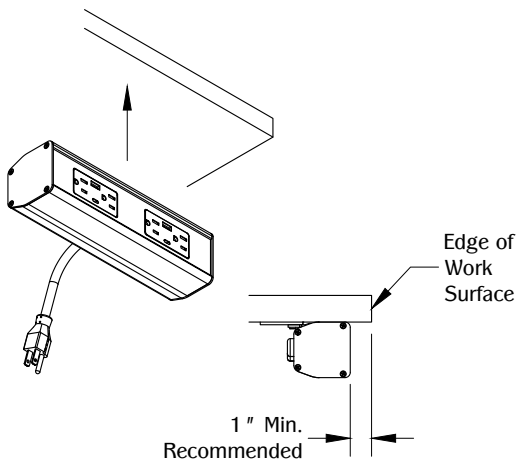

Determine position and location of the unit under the work surface. DO NOT place unit where cable is strained or trapped.

1

UNDER MOUNT

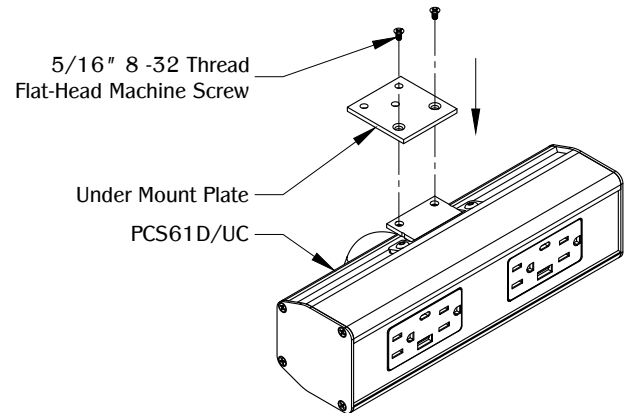

Attach the under mount plate to the unit by using (2) 5/16" 8-32 thread flat-head machine screw.

3

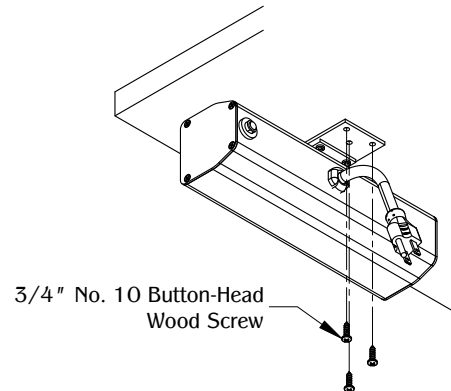

Secure the unit under the work surface by using (3) 3/4" No. 10 button-head wood screw. Plug into nearby outlet and unit is ready for use.