

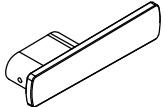







PROPRIETARY AND CONFIDENTIAL. All dimensions have a (+/-) 1/32" tolerance unless otherwise specified. We do not recommend drilling or cutting any holes before receiving a product or a product sample.

SPECIFICATIONS

- Weight capacity is 25 lbs. installed into drywall with metal anchors.
- Weight capacity is 25 lbs. installed into studs.

TABLE OF CONTENTS

 1X HK40 Top
 1X HK40 Bottom
 1X 1-1/2" No. 8 at 5/8" 8-32 Thread at 7/8" Hanger Bolt
 1X HK40 Base
 2X 1-3/4" No. 8 Pan Head Wood Screw
 1X 8-32 Thread Binding Barrel
 3X HK-Anchor
 2X M4 X 0.7 X 5.00mm Set Screw

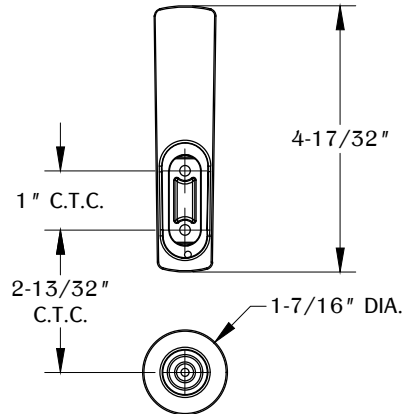
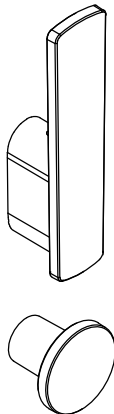

REAR VIEW

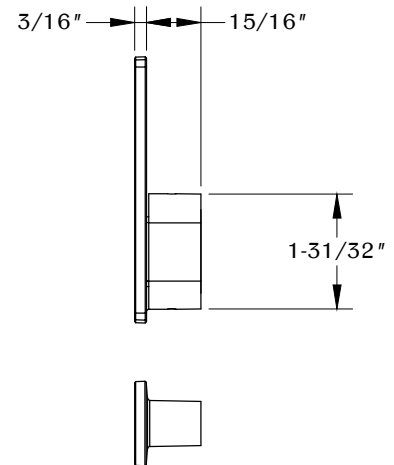

RIGHT VIEW

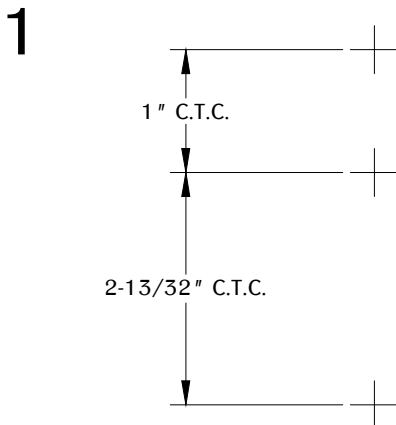

Determine the position and location of the part on the work surface. Mark the mounting positions for the mounting hardware.

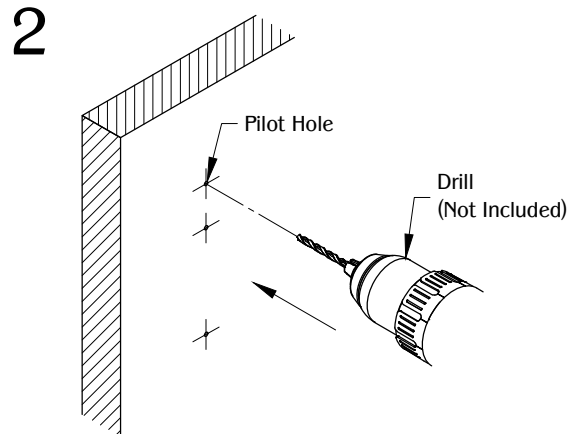

Drill 3/16" diameter pilot holes for drywall installation or 3/32" diameter pilot holes for stud installation.

PROPRIETARY AND CONFIDENTIAL. All dimensions have a (+/-) 1/32" tolerance unless otherwise specified. We do not recommend drilling or cutting any holes before receiving a product or a product sample.

3

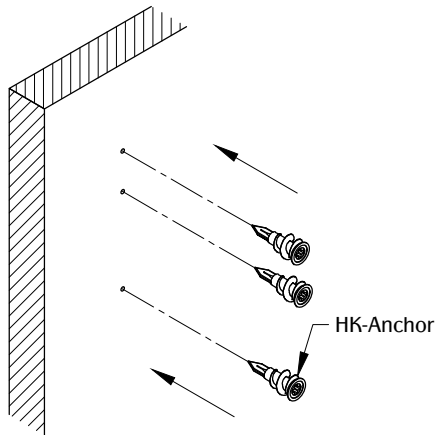

Install (3) HK-Anchor into the pilot holes. For drywall use only. (Note: Skip this step for stud installation.)

4

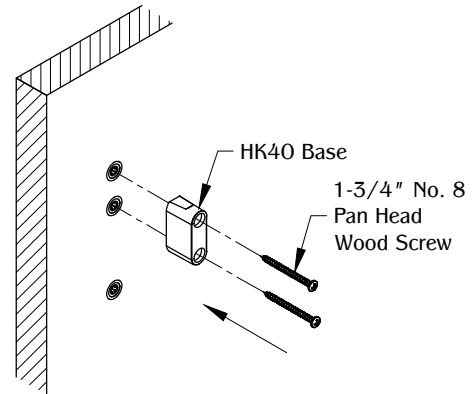

Position the HK40 base so it aligns with either the pre-drilled pilot holes or the installed HK-Anchors. Then, use (2) 1-3/4" No. 8 pan head wood screws to secure it. Make sure the HK40 base is level onto the work surface.

5

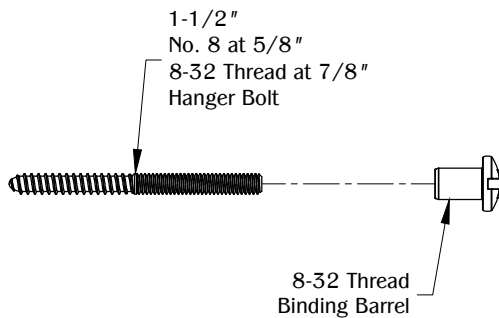

Align and secure by turning the 8-32 thread binding barrel clockwise onto the machine threads side of 1-1/2" No. 8 at 5/8" 8-32 thread at 7/8" hanger bolt.

6

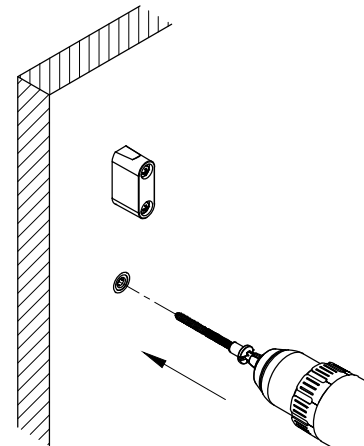

Install hanger bolt into HK-Anchor or pilot hole. Once the hanger bolt is installed, unscrew the binding barrel from hanger bolt.

7

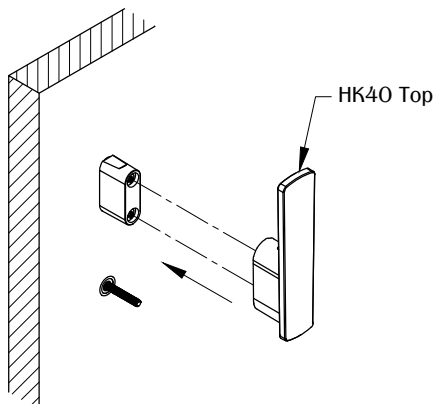

Install the HK40 top on the HK40 base, making sure it is level and aligned.

8

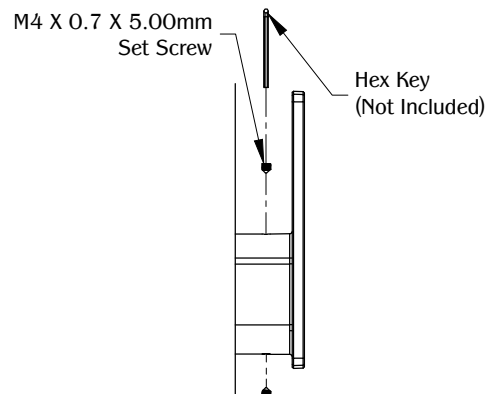

SIDE VIEW

To secure part using (2) M4 X 0.7 X 5.00mm set screws and hand tighten with a hex key.

PROPRIETARY AND CONFIDENTIAL. All dimensions have a (+/-) 1/32" tolerance unless otherwise specified. We do not recommend drilling or cutting any holes before receiving a product or a product sample.

9

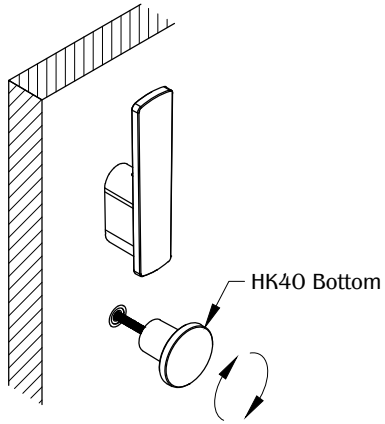

Align the HK40 bottom to the hanger bolt and secure by turning clockwise.