

DP324

PROPRIETARY AND CONFIDENTIAL.
ALL DIMENSIONS HAVE A +/- 1/32" TOLERANCE UNLESS OTHERWISE SPECIFIED. WE DO NOT RECOMMEND DRILLING OR CUTTING ANY HOLES BEFORE RECEIVING A PRODUCT OR A PRODUCT SAMPLE.

SPECIFICATIONS

- Additional mounting screw lengths available upon request.

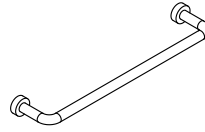

..... 1X DP324



..... 2X 1" M4 X 0.70 Thread Mounting Screw

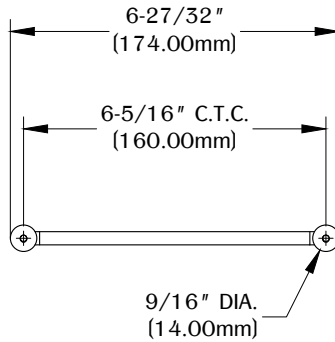
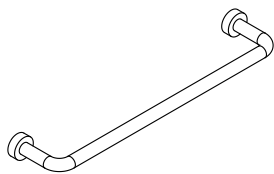

REAR VIEW

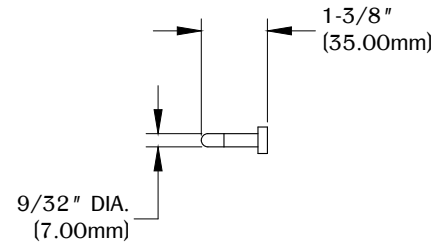

RIGHT VIEW

1

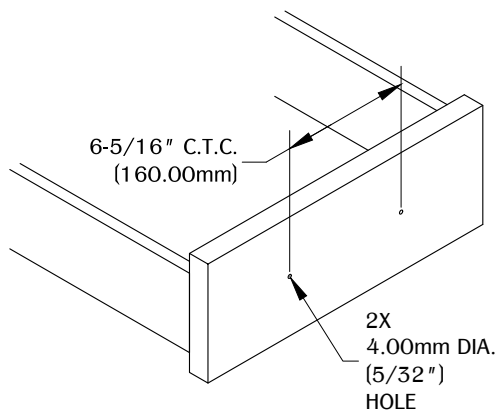

Determine the position and location of the part on the work surface. Mark the mounting positions and drill the hole for the mounting hardware.

2

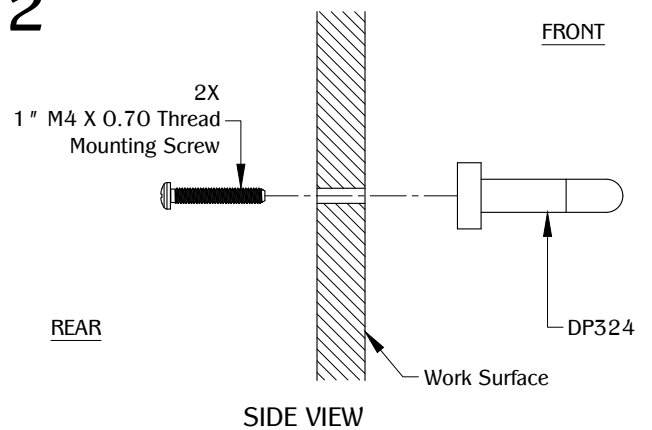

Use (2) 1" M4 X 0.70 thread mounting screw to secure the part to the work surface. Make sure the part is fully level on the work surface.