

DP310

PROPRIETARY AND CONFIDENTIAL.
ALL DIMENSIONS HAVE A +/- 1/32" TOLERANCE UNLESS OTHERWISE SPECIFIED. WE DO NOT RECOMMEND DRILLING OR CUTTING ANY HOLES BEFORE RECEIVING A PRODUCT OR A PRODUCT SAMPLE.

SPECIFICATIONS

- Additional mounting screw lengths available upon request.

TABLE OF CONTENTS

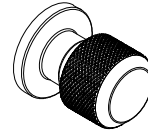

..... 1X DP310



..... 1X 1" M4 X 0.70 Thread Mounting Screw

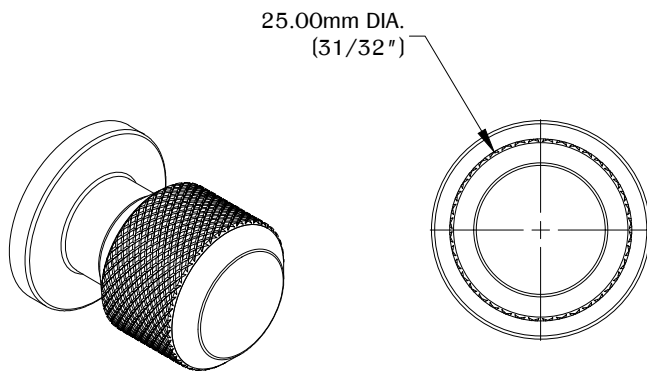

FRONT VIEW

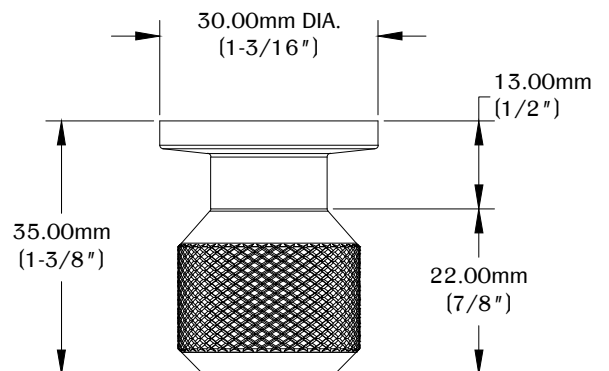

TOP VIEW

1

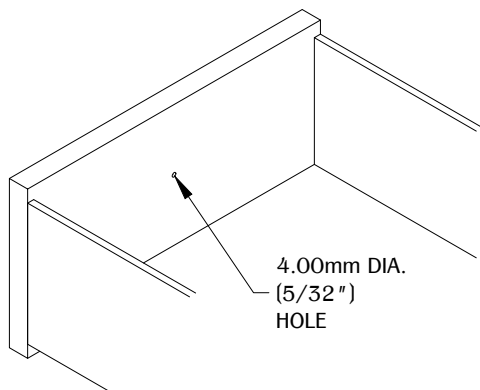

4.00mm DIA. (5/32") HOLE

Determine the position and location of the part on the work surface. Mark the mounting position and drill the hole for the mounting hardware.

2

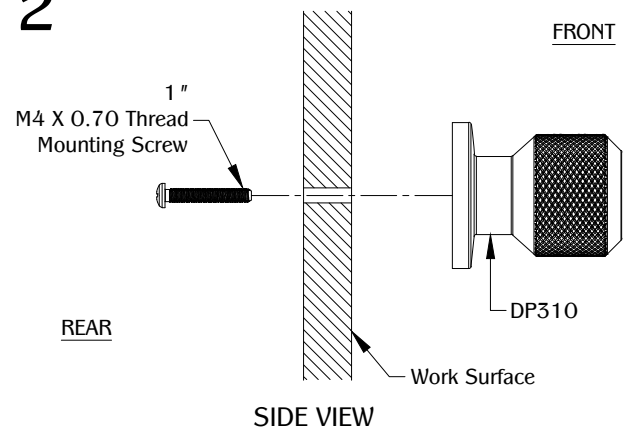

SIDE VIEW

Use (1) 1" M4 X 0.70 thread mounting screw to secure the part to the work surface. Make sure the part is fully level on the work surface.