

RIGHT VIEW

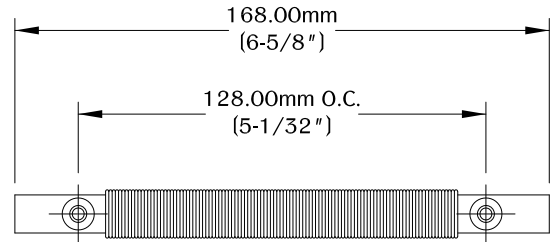

REAR VIEW

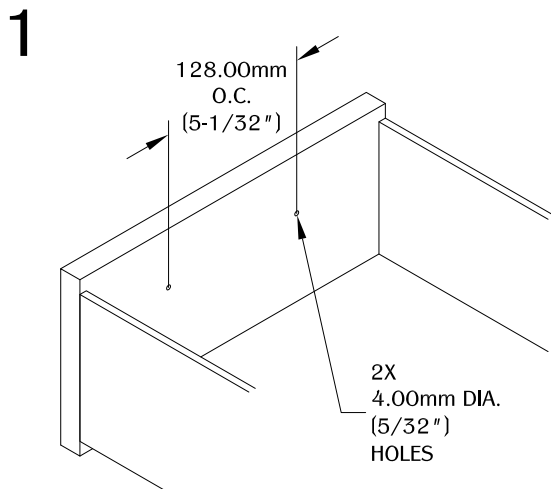

Determine the position and location of the part on the work surface. Mark the mounting positions and drill the holes for the mounting hardware.

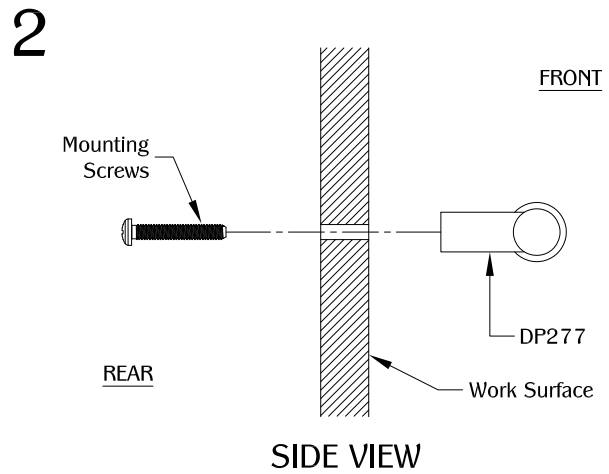



Use (2) screws to secure the part to the work surface. Make sure the part is fully level on the work surface.

**NOTE:**

- Additional mounting screw lengths available upon request.
- All dimensions have a  $\pm 1/32$ " tolerance. We do not recommend drilling or cutting any holes before receiving a product or a product sample.

**TABLE OF CONTENTS:**

|   |  |
|---|--|
|  | .....1X DP277                                      |
|  | .....2X 1-3/16"<br>4mm-70 thread<br>Machine screws |