

	(A) Length	(B) O.C.	HOLE COUNT
DP3	1-1/4"	5/8"	2
DP3A	3"	2"	2
DP3B	4"	3"	2
DP3C	6"	5"	2
DP3D	8"	3"	3
DP3E	10"	4"	3
DP3F	12"	3-5/16"	4
DP3G	14"	4"	4
DP3H	16"	4-21/32"	4
DP3I	18"	5-11/32"	4
DP3J	20"	6"	4
DP3K	22"	6-21/32"	4
DP3L	24"	7-11/32"	4

NOTE:

- All dimensions have a $\pm 1/32"$ tolerance. We do not recommend drilling or cutting any holes before receiving a product or a product sample.

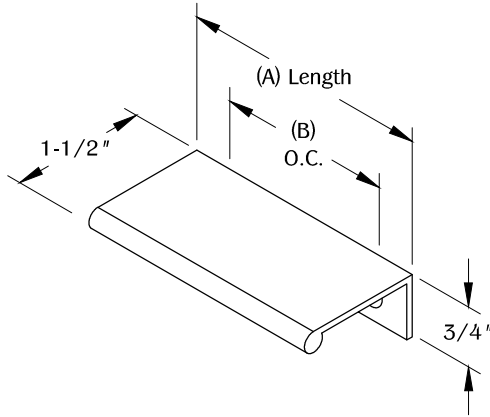

1a SURFACE MOUNT

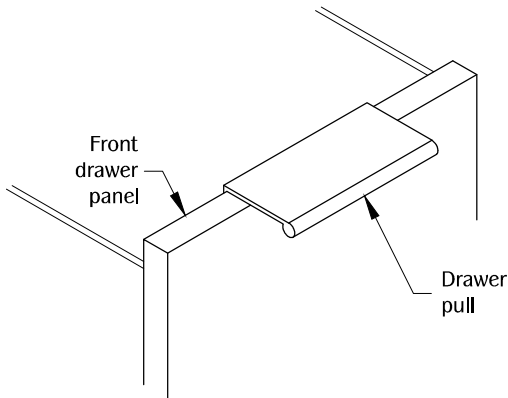

Determine the position and location of the part in the work surface. Center the part on top of the front drawer panel.

2a

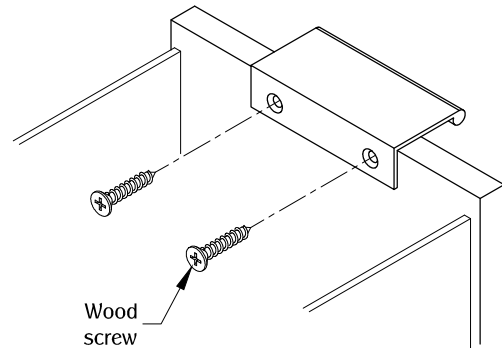

Secure with (2) mounting screws.
(Note: Mounting holes and hardware varies by size see chart.)

3a

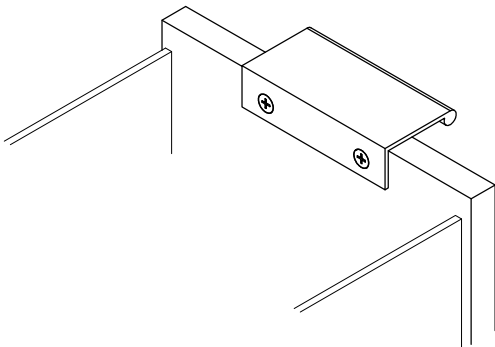
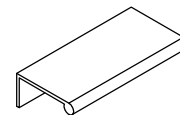

TABLE OF CONTENTS:



..... 1X Drawer pull



..... 1/2" No. 6 Flathead wood screws
(Quantity varies by size.)

1b FLUSH MOUNT

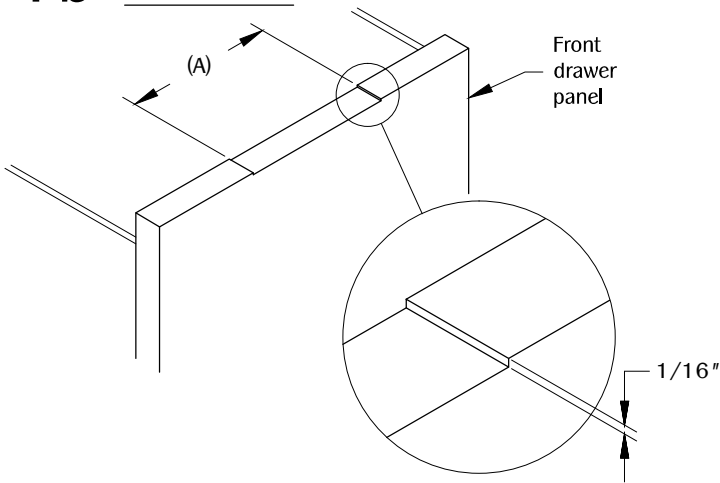

Determine the position and location of the part in the work surface. Rout the top of the front drawer panel. (See page 1 chart for length.)

2b

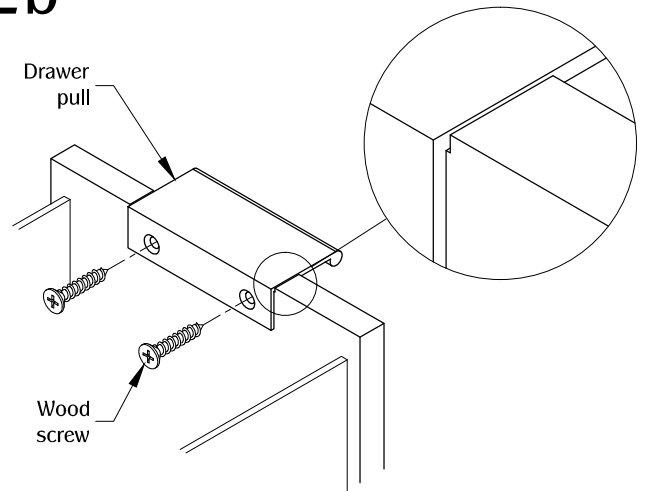

Install the part flushed into the routed surface. Secure with (2) mounting screws. (Note: Mounting holes and hardware varies by size see chart.)

3b

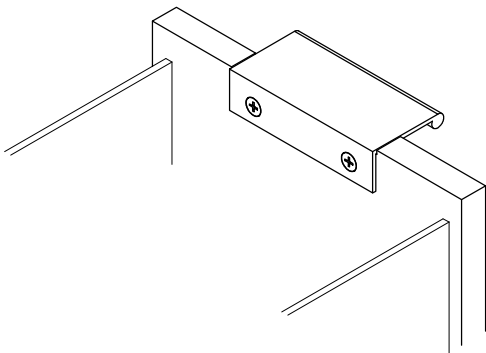

1c FRONT SURFACE MOUNT

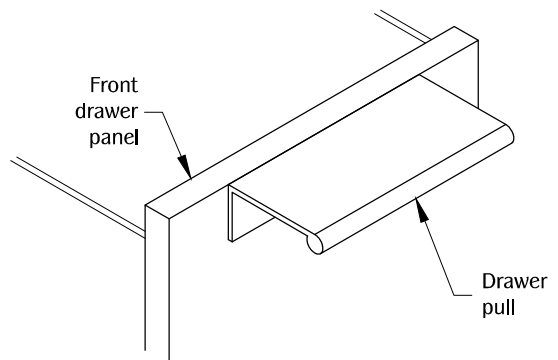

Determine the position and location of the part in the work surface.

2c

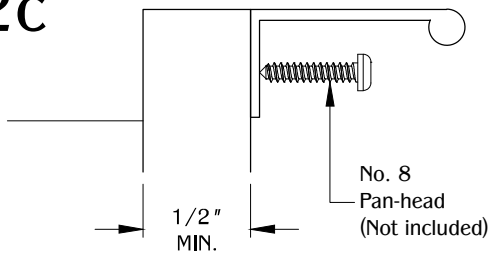

Center the part on the top front drawer panel and secure with (2) mounting screws.

(Note: Mounting holes and hardware varies by size see chart. Flat head screws included with part is not recommended for this option. Use appropriate screw length depending on the drawer panel thickness.)

3c

