

MOCKETT

DESIGN • QUALITY • SERVICE

PO Box 3333

Manhattan Beach, CA 90266

Questions? Please call
(800) 523-1269

Complete form and send to
custom@mockett.com or fax to: **(310) 376-7650**

CUSTOM DEPARTMENT FORM - Table Leg TL Series

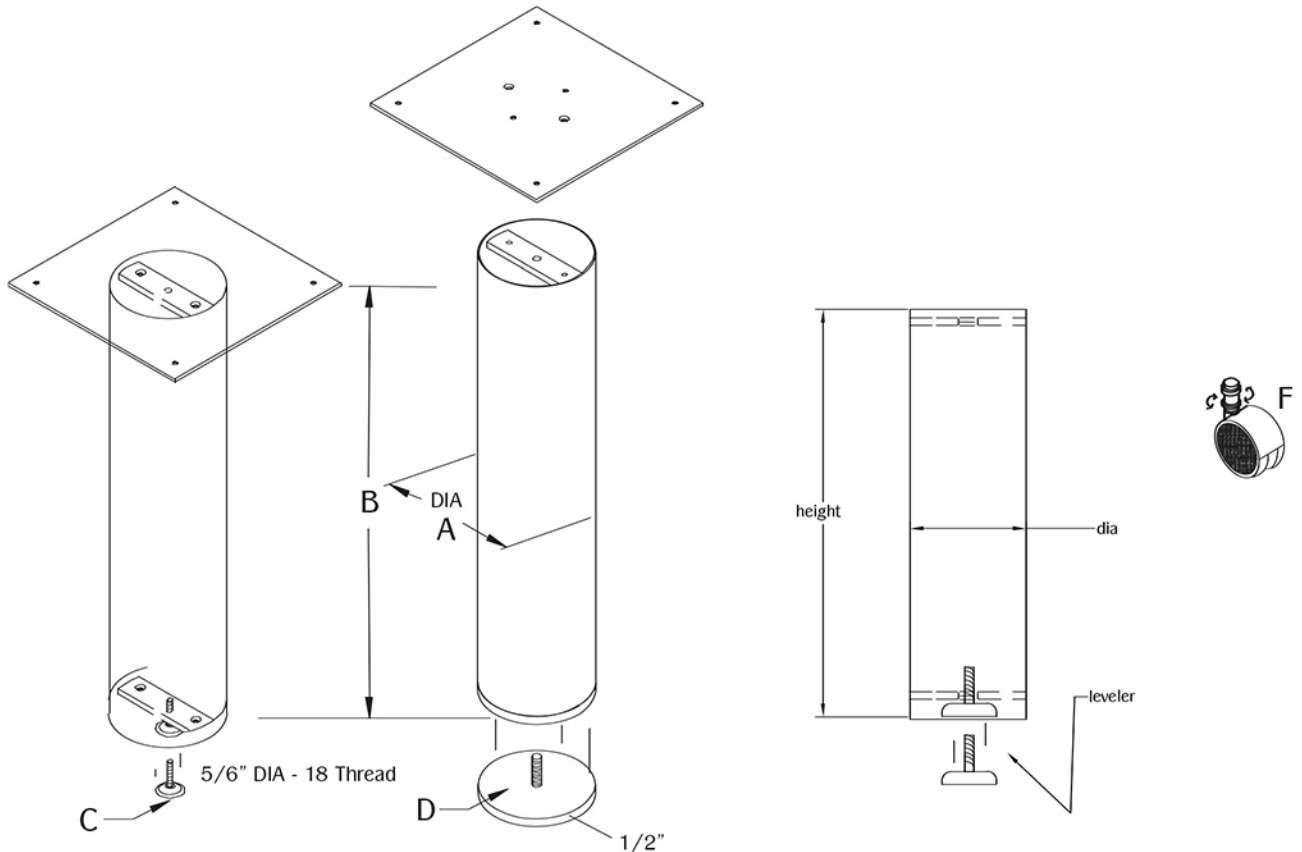

Specify

A

1", 2", 3", 4"

_____ DIA

Enter Size

B

Height

_____ Overall

Overall

Leveler Options

C

Regular Leveler

D

Plate Leveler

Same Diameter as Leg

Caster Options

F

2"

Plastic w/Lock

- Unfinished
- Matte Black
- Satin Chrome
- Polished Chrome

Finishes

- Satin Stainless Steel
- Polished Stainless Steel
- Custom Finish (Provide sample)

Quantity

Company: _____

Phone: _____

Contact: _____

Fax: _____

Comments:

Email: _____